

Side-pumped slab lasers with Tm, Er or Yb doping

Alex Dergachev, Yelena Isyanova, Bhabana Pati,
Kevin Wall and Peter Moulton
Q-Peak, Inc.

SSDLTR 2002
Albuquerque, NM
6 June 2002



- **Background of Nd-doped systems**
- **Tm:YLF laser for optical pumping**
- **Er:YLF laser as mid-IR, cw source**
- **Yb:S-FAP laser for energy storage**
- **Summary**



MPS design obtains high efficiency and high beam quality with side-pumping

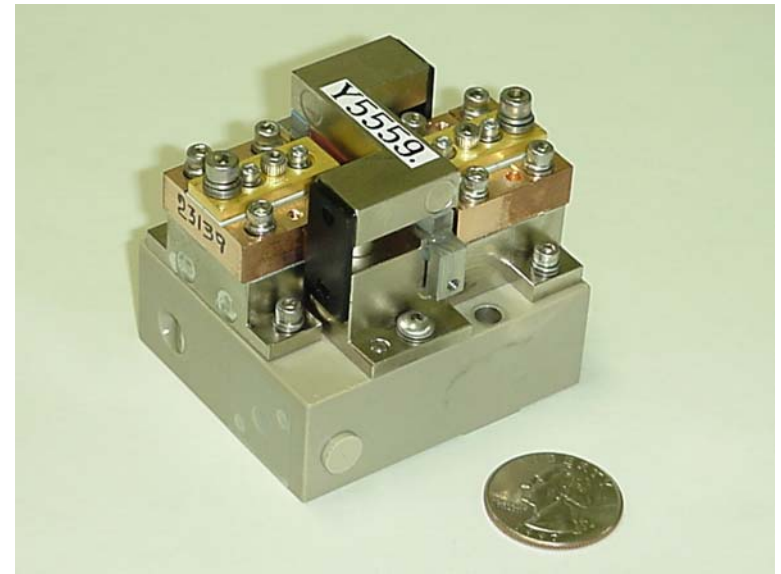
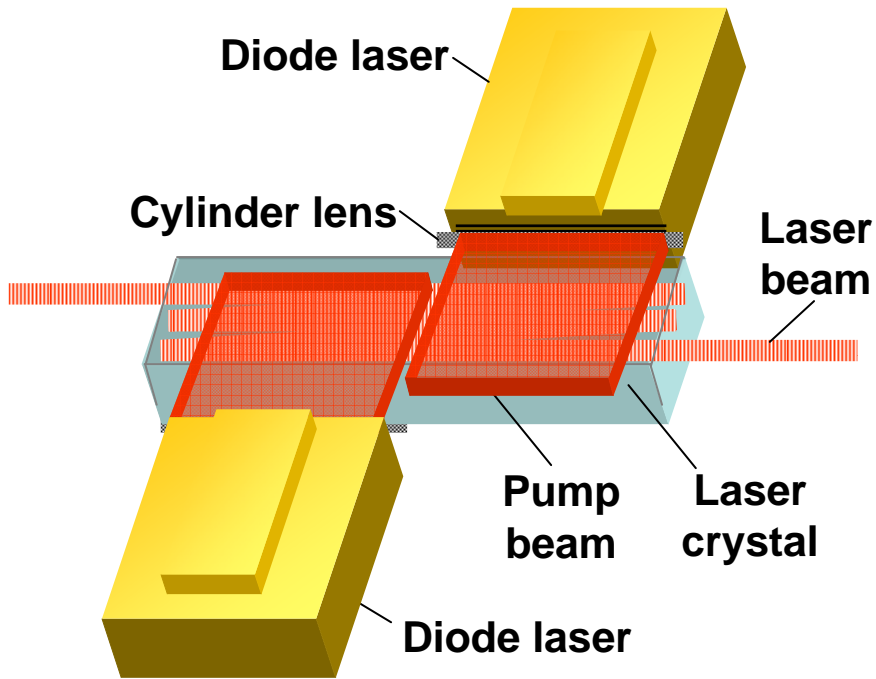

Multi-Pass Slab (MPS)
US Patent 5,774,489

“Gain Module”

Oscillator

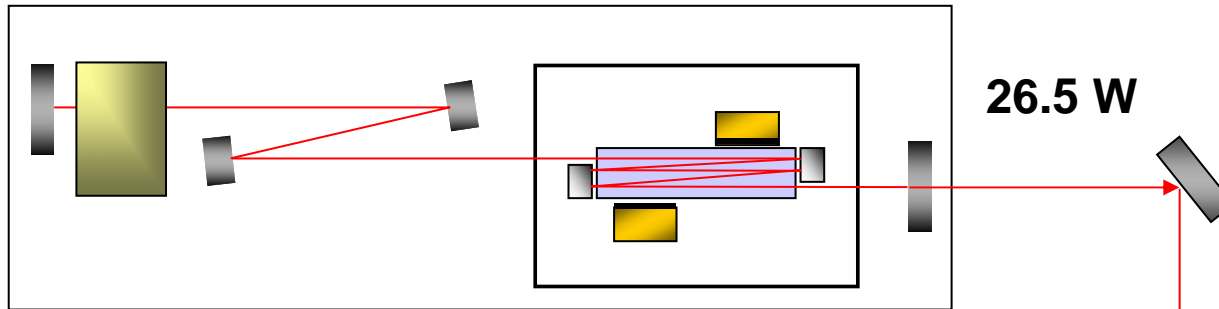

Gain Modules

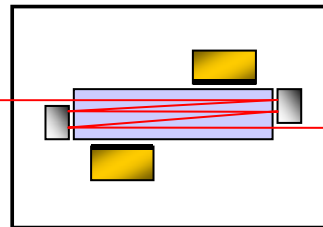

Amplifier

**54 W cw,
>50 W Q-switched
with 128 W
total pump
 $M^2 \approx 1.15$**

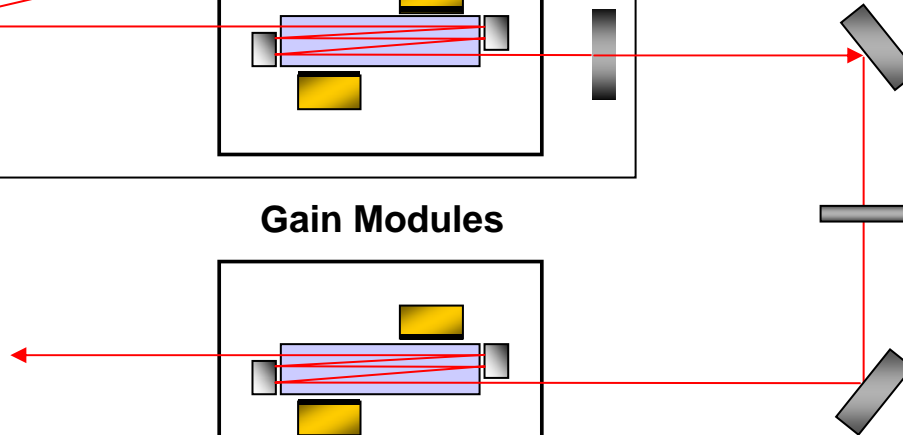

High-power, MPV (Nd:YVO₄) gain module

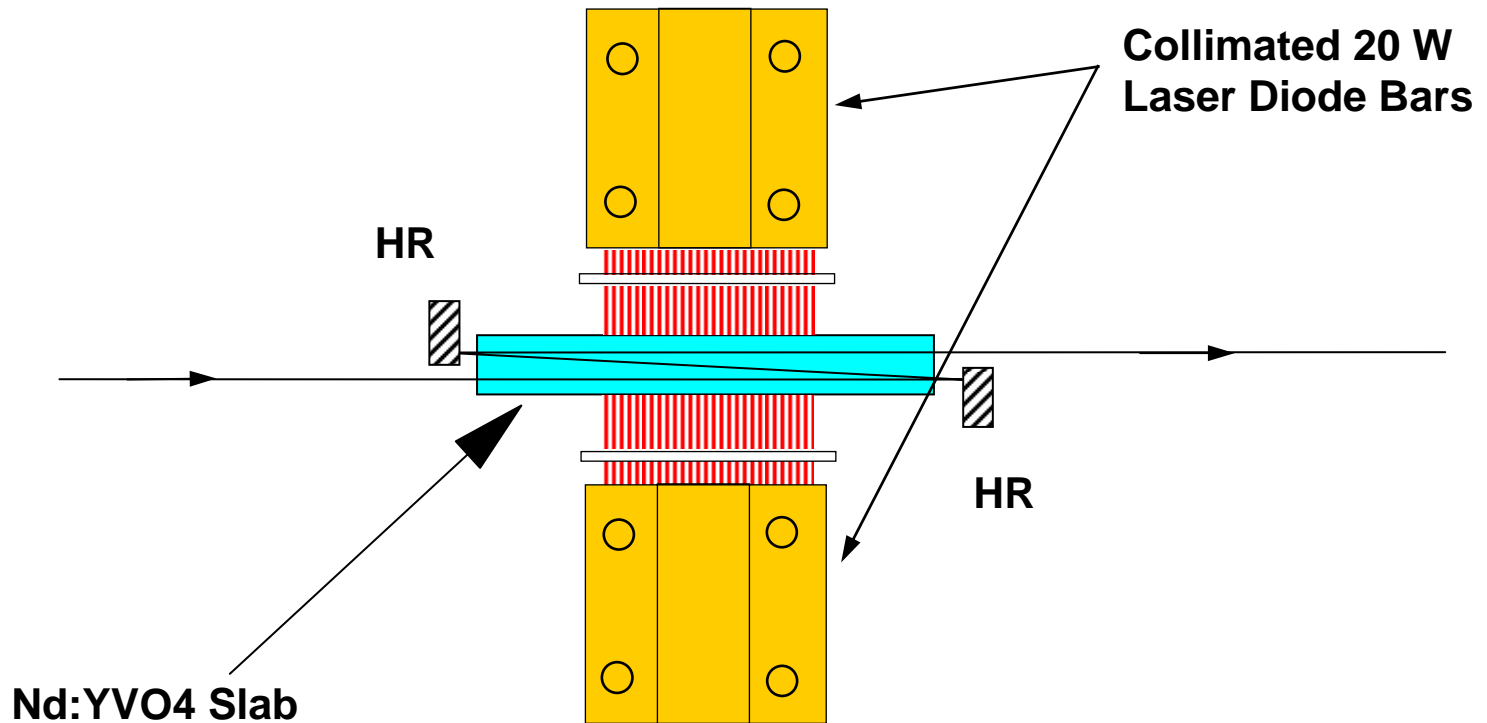

Amplified microlaser with 400-ps pulsewidth

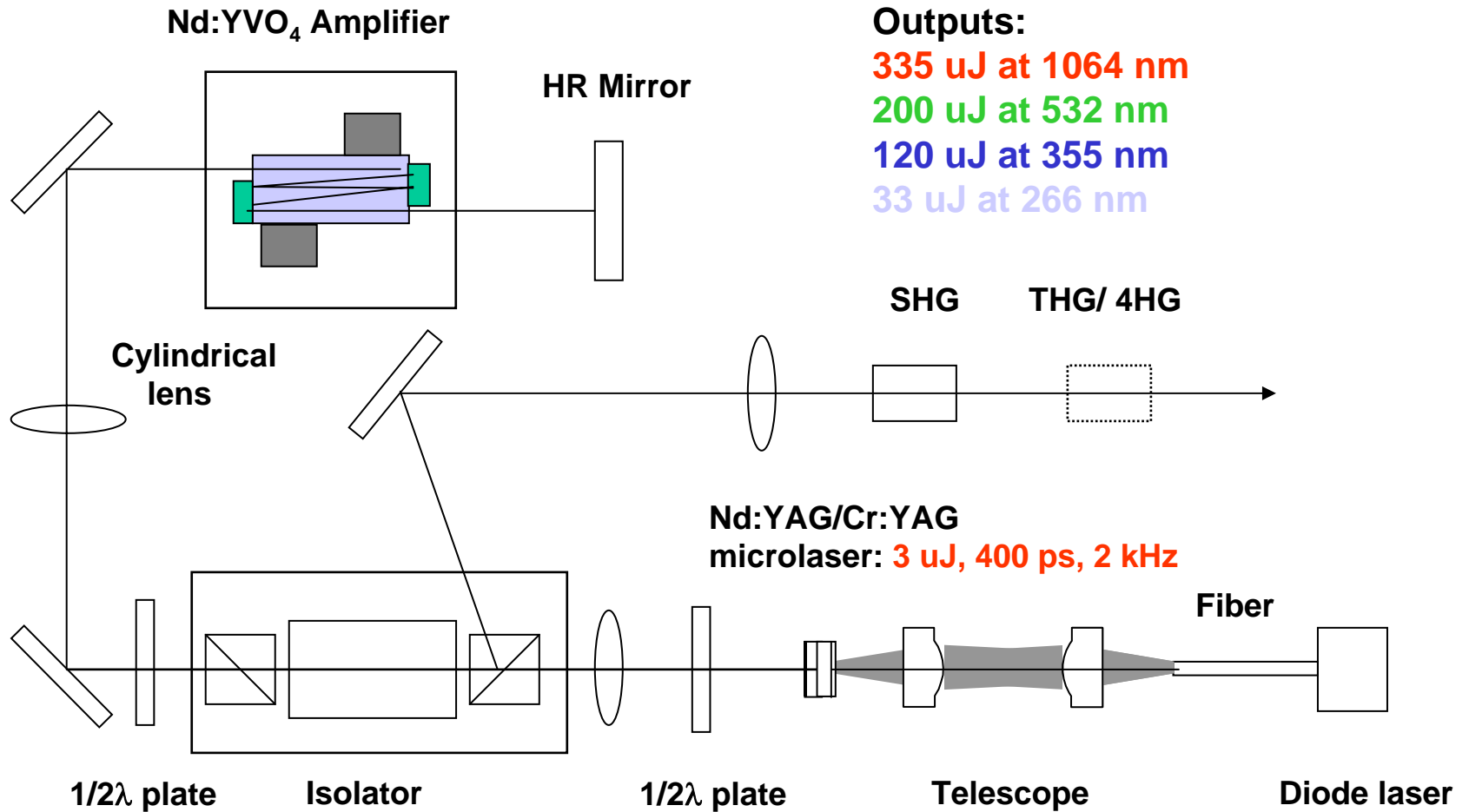

More examples of amplifier systems

700 mW CW
at 1064-nm
Single-frequency

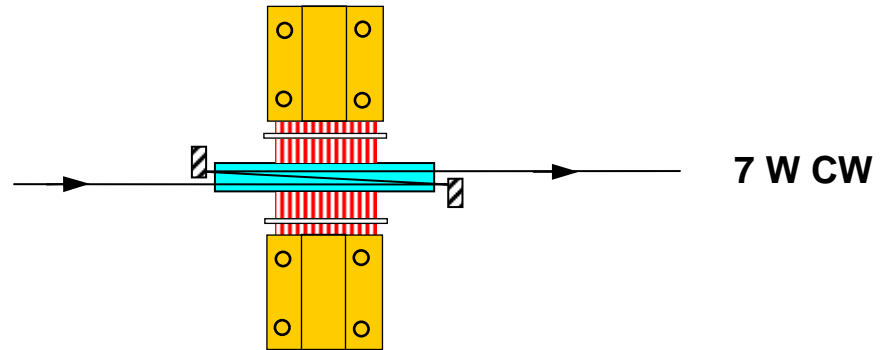

700 mW
4.7-ps pulses
@ 100 MHz
1047 nm

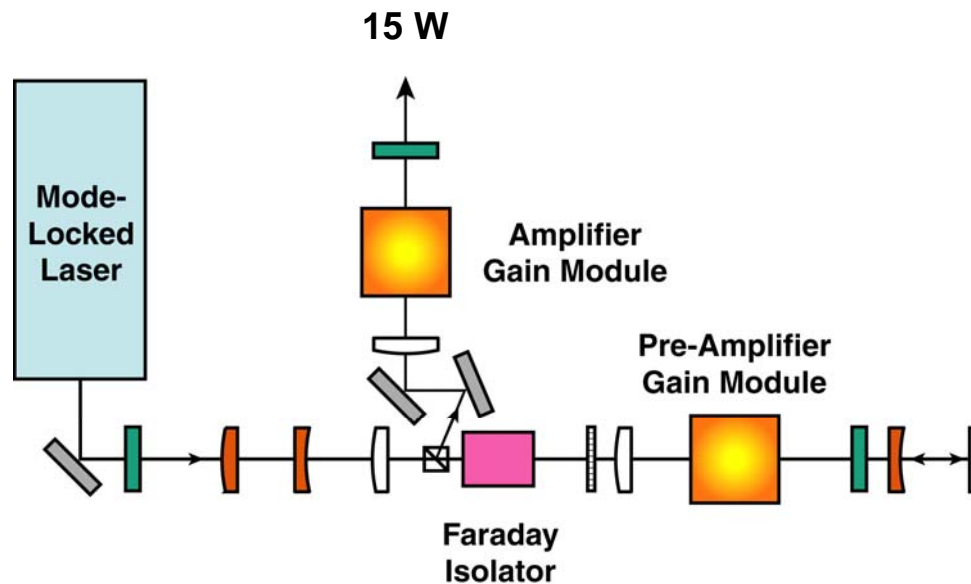

Pumping of Ho-doped laser crystals

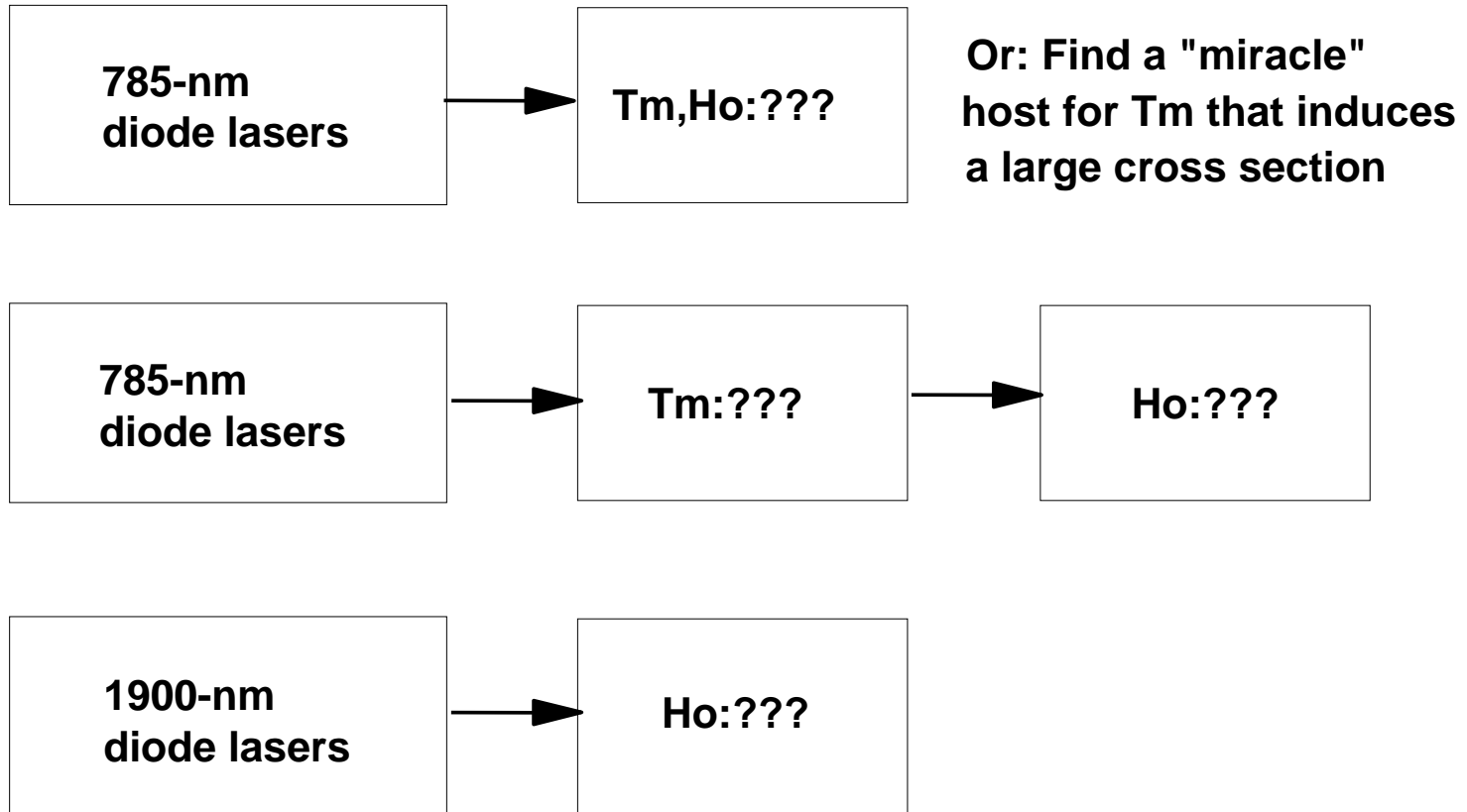

Energy levels in Tm:YLF

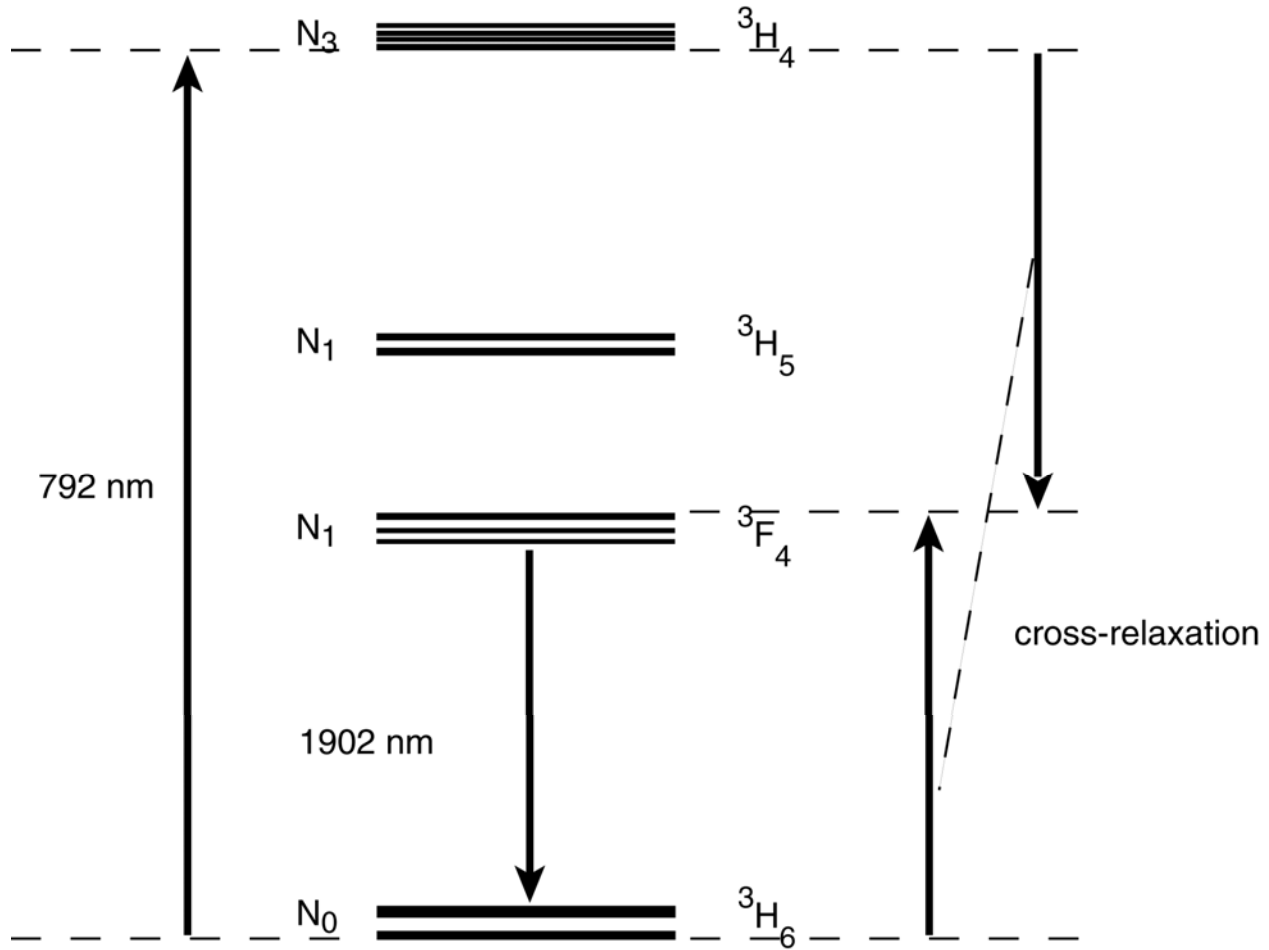

Absorption bands in Tm:YLF overlap high-power, efficient AAA diode lasers

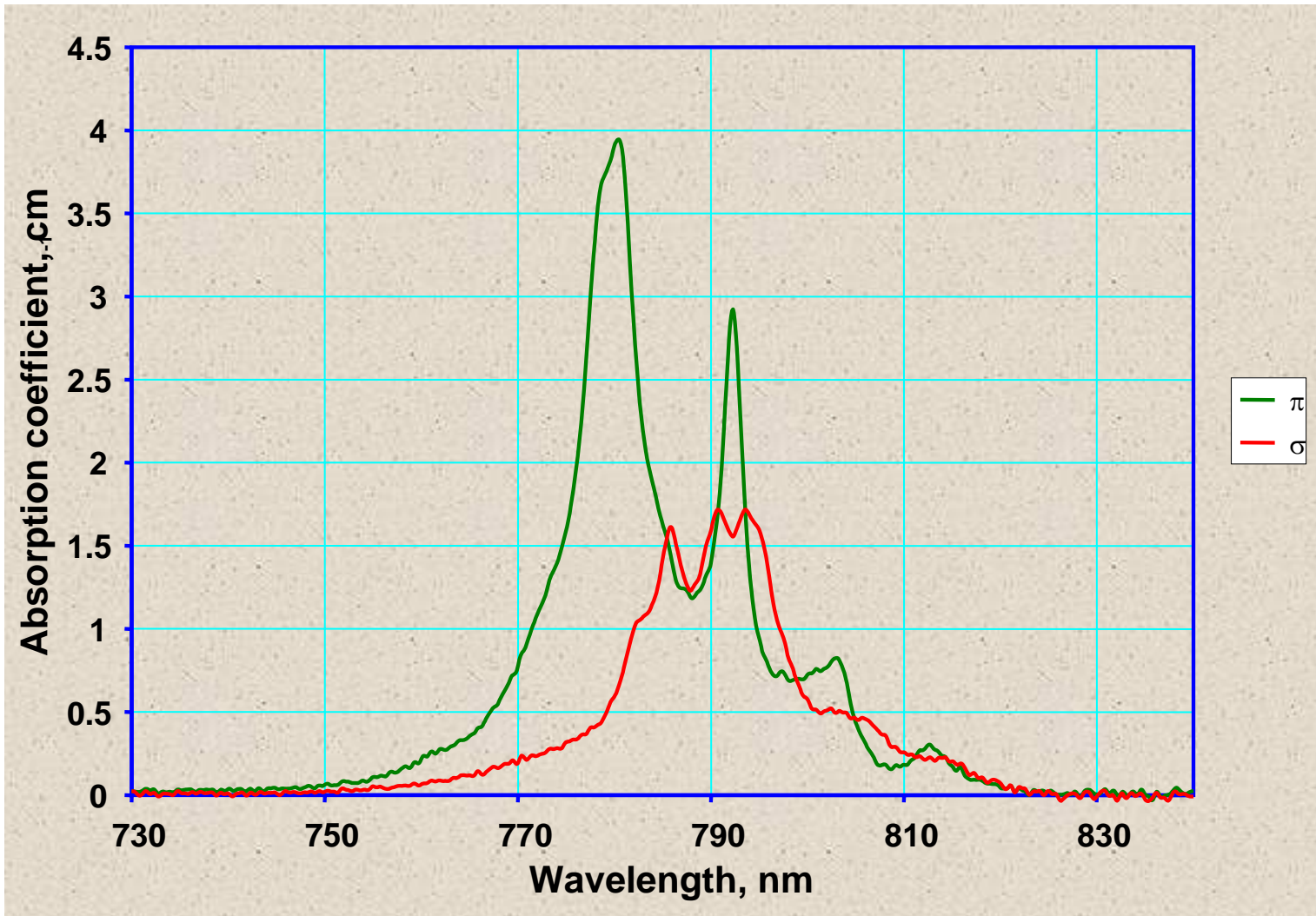

Gain peak, polarization in Tm:YLF laser depends on inversion density

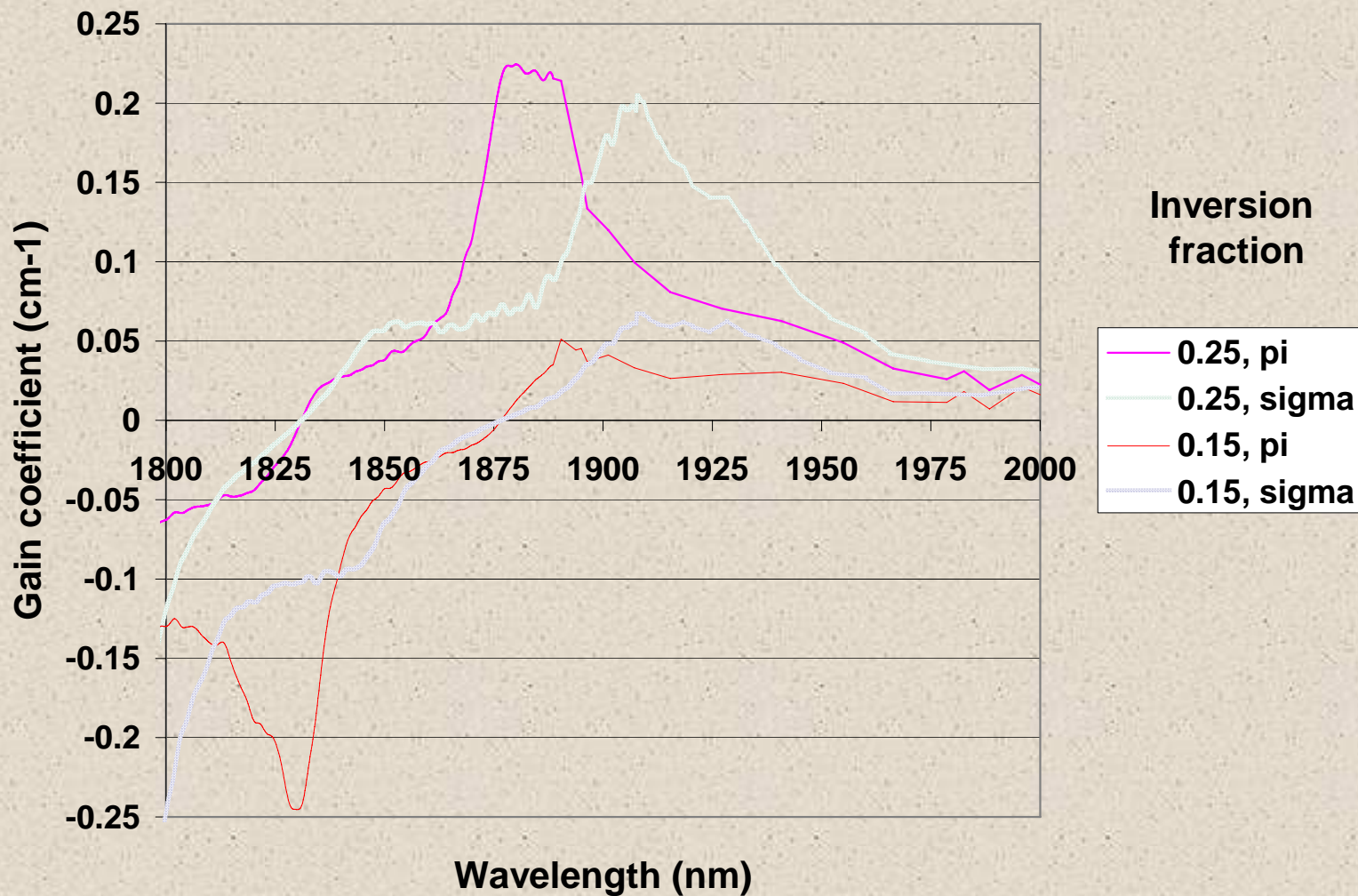



MPS Tm:YLF laser generates 18 W at 1960 nm

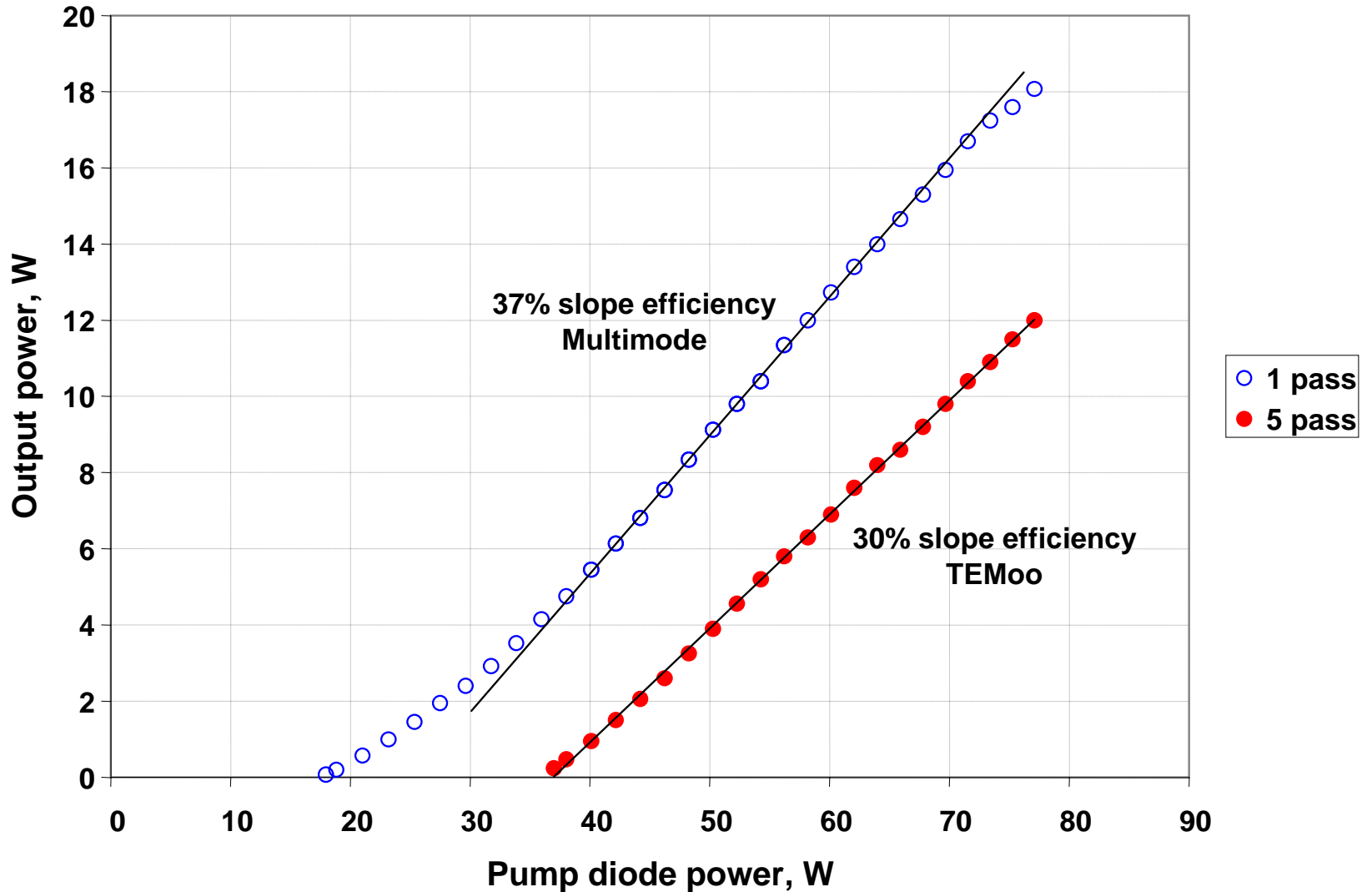

Tunable power from Tm:YLF laser

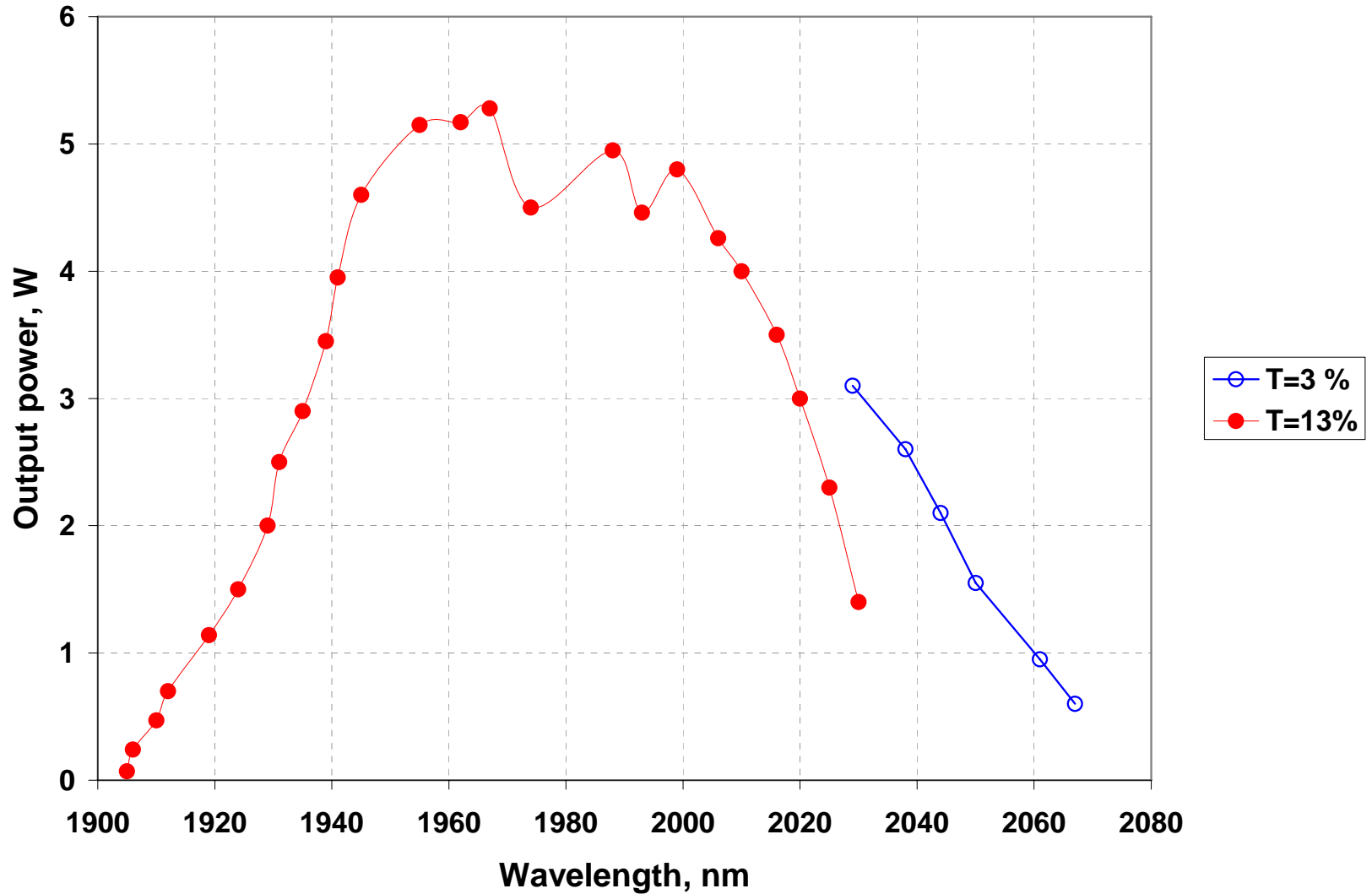

Level diagram, pump and laser transitions in Ho:YLF

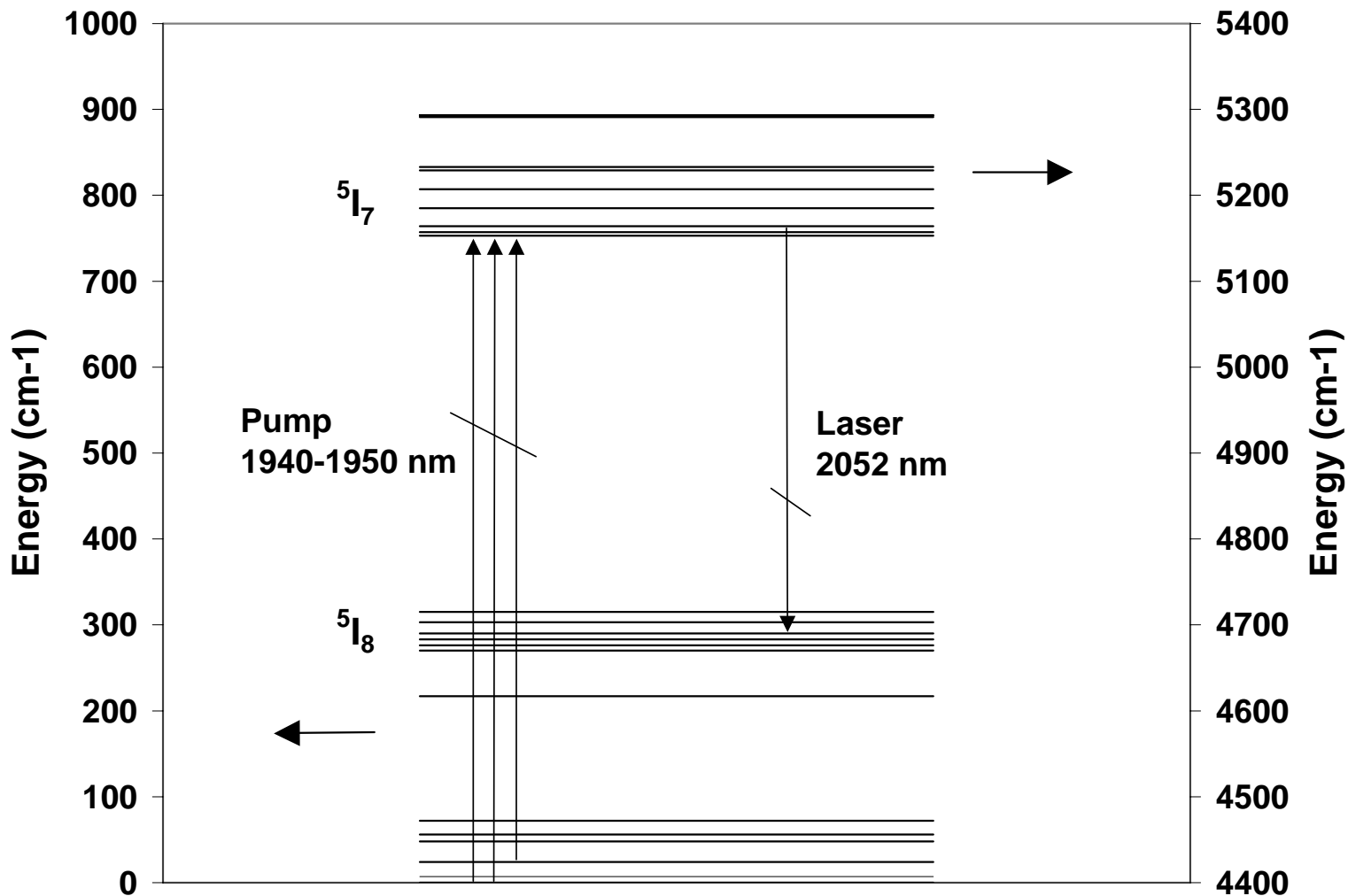

Energy levels in Er:YLF (partial)

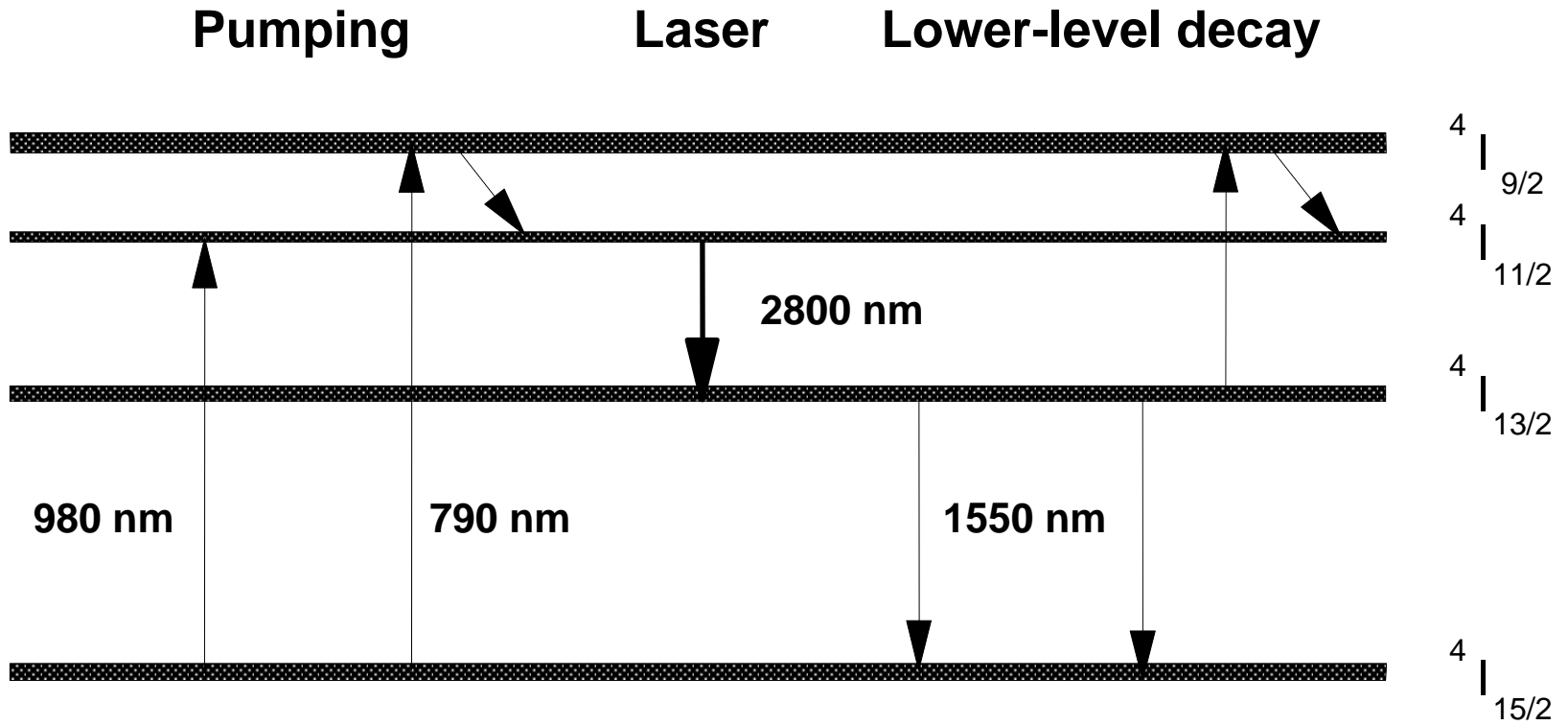

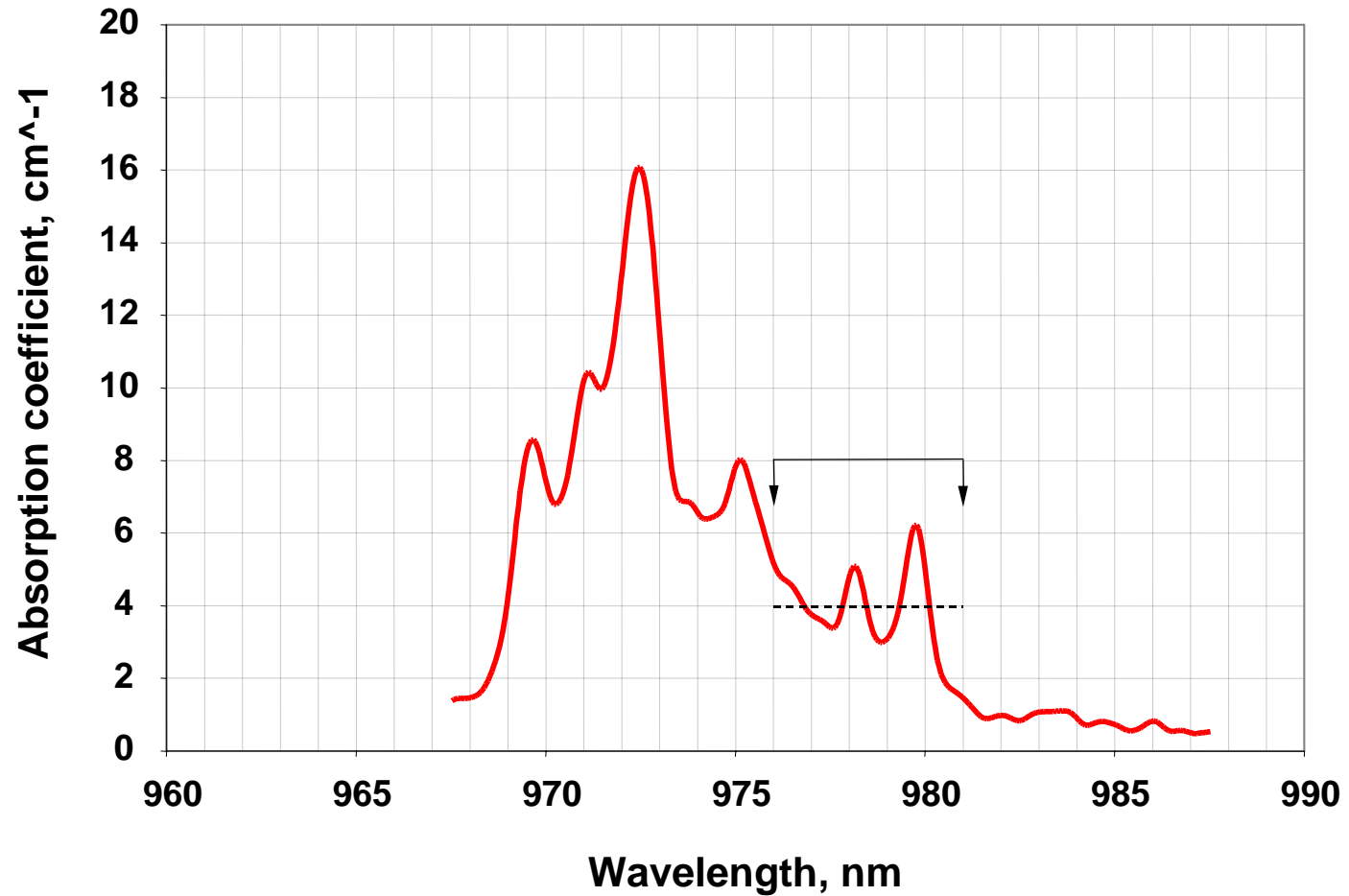

Brewster-angle design for Er:YLF medium

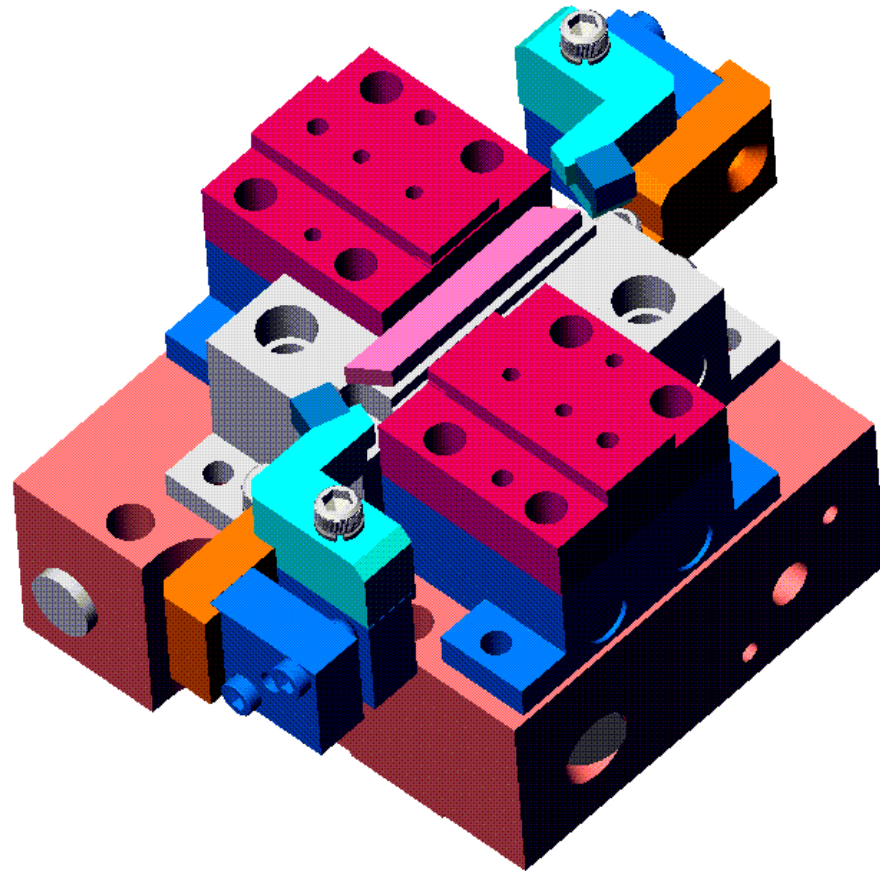

I/O curves for cw Er:YLF laser at 2810 nm

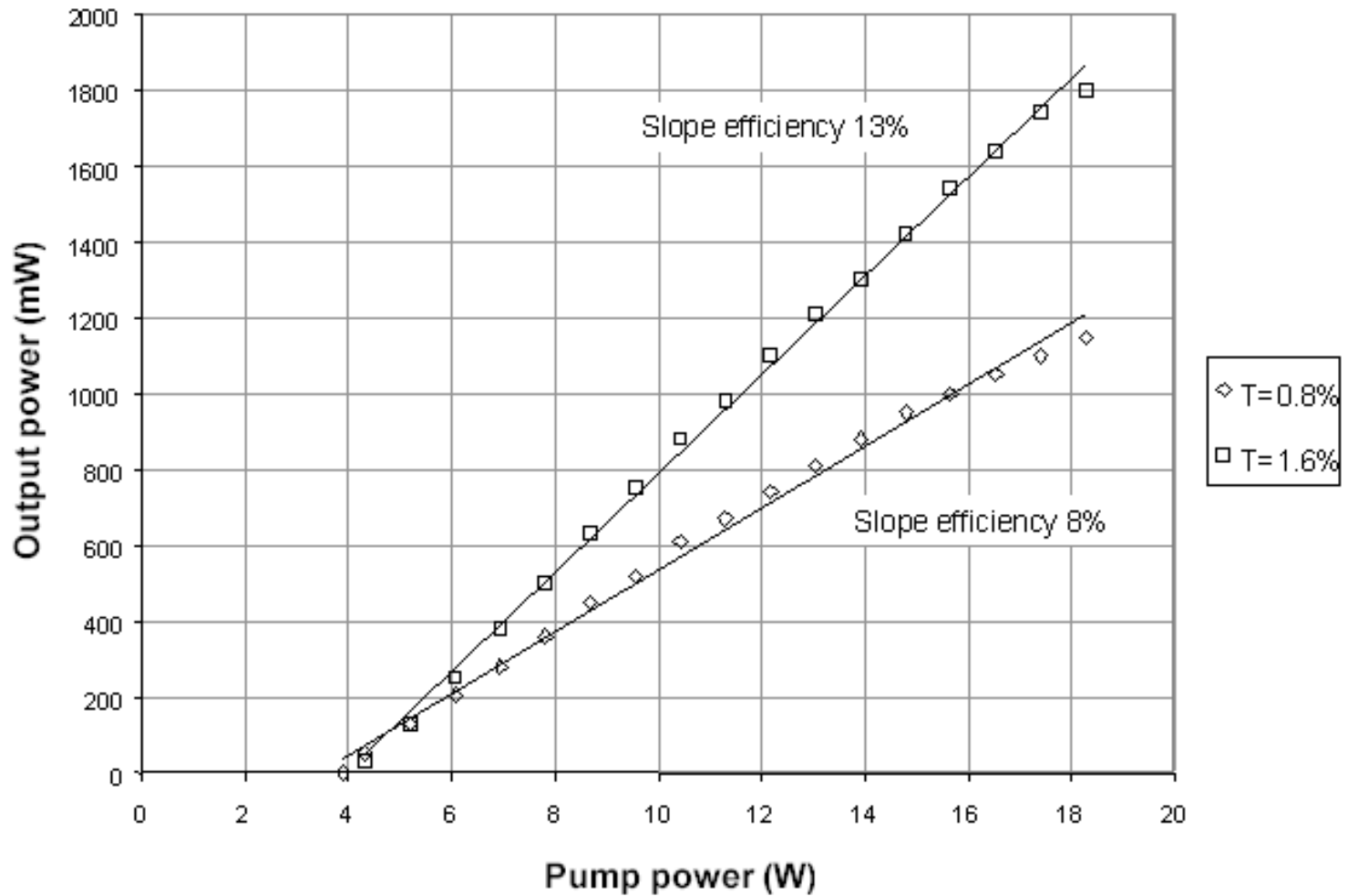

Fluorescence, laser operation from Er:YLF overlaps HF laser spectrum

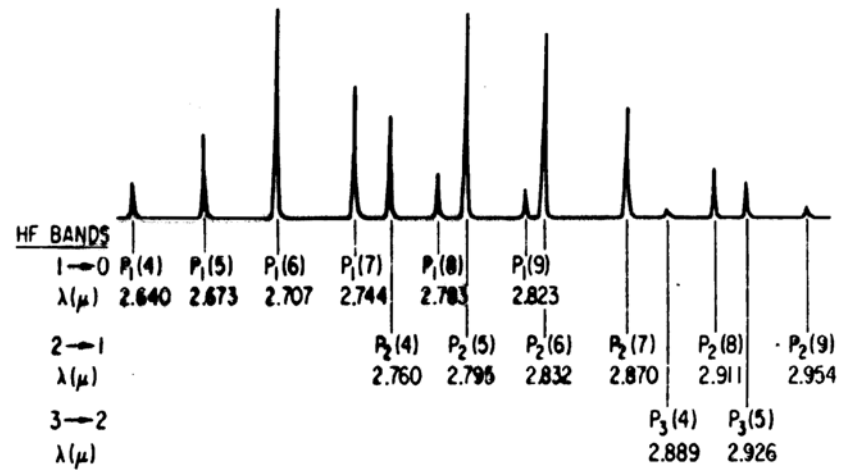
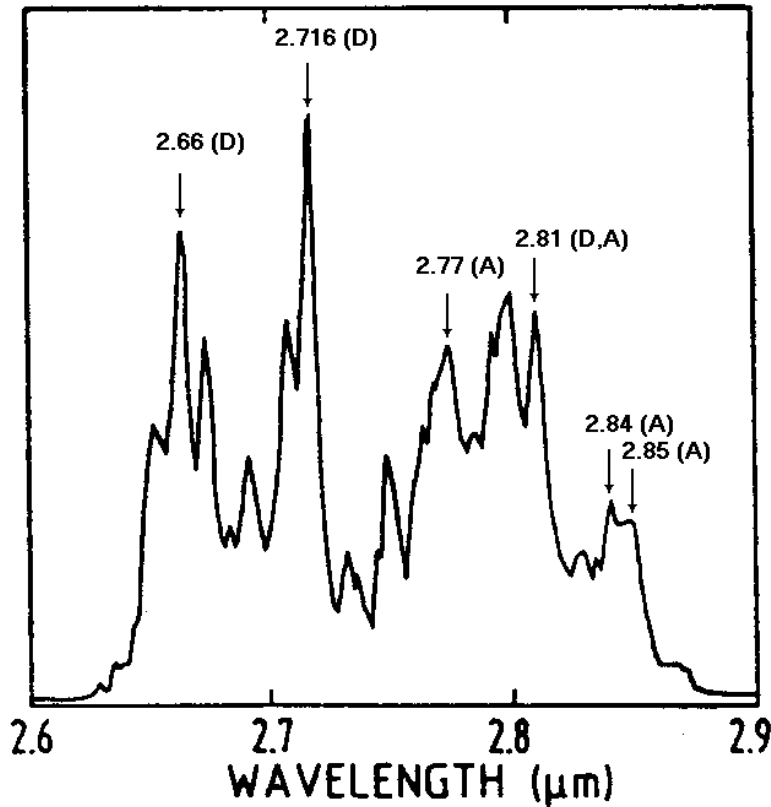



Comparison of different laser media

	Nd:YAG	Nd:YLF	Yb:YAG	Yb:S-FAP
Laser Wavelength (nm)	1064	1047	1029	1047
Upper State Lifetime (ms), τ	0.24	0.522	1.16	1.26
Stimulated Emission Coefficient (10^{-20} cm^2), σ	28	19.6 (π)	2.1	7.3 (π)
$\sigma \tau$ Product ($10^{-20} \text{ cm}^2 \text{ ms}$)	6.7	10.2	2.0	9.2
Quantum Defect	0.76	0.76	0.90	0.86
Pump Saturation Intensity			28	2.0
Thermal Conductivity ($\text{W m}^{-1} \text{ K}^{-1}$)	13	6	13	2.0
Fracture Toughness ($\text{MPa/m}^{1/2}$)	1.4	0.27	1.4	0.51

Advantages

- **Birefringent material**
- **Simple two-level structure**
 - No ESA, upconversion
- **Low quantum defect**
 - Low heat generation (~14%)
- **Adequate gain cross section**
- **Long upper laser level lifetime**
~ 1.26 ms
 - Provides good energy storage with diode pumps
- **Under extensive development at LLNL for Mercury Program**
- **Overlaps Nd:YLF laser line**

Drawbacks

- **Quasi-four level operation**
- **Narrow absorption bandwidth ~ 3-4 nm**
 - Stringent requirements on the pump diode linewidth and wavelength

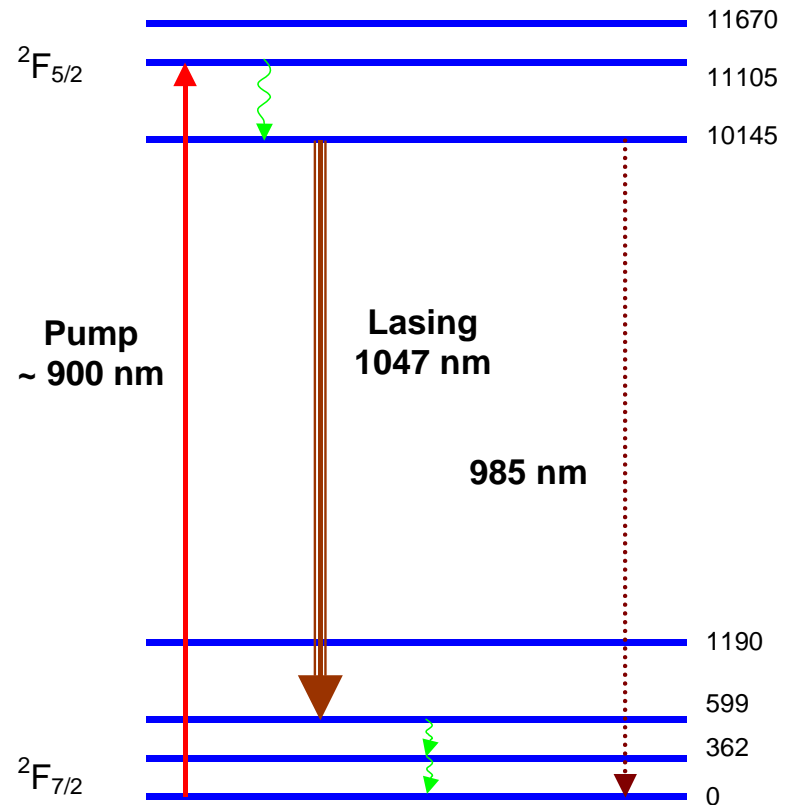



Comparison of Nd:YLF and Yb:S-FAP cw-pumped, repetitively Q-switched

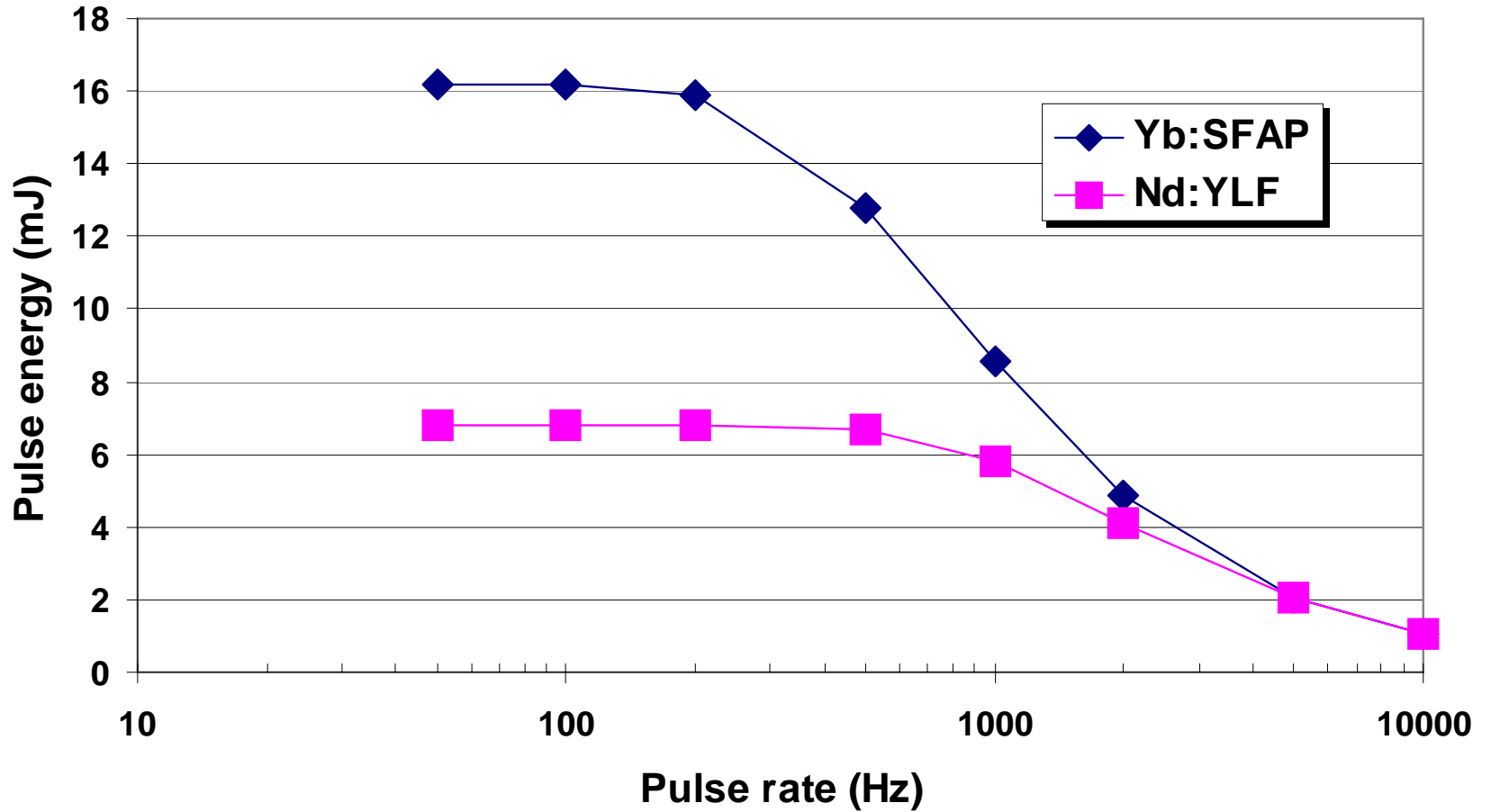

Yb:S-FAP pump band peaks at 900 nm

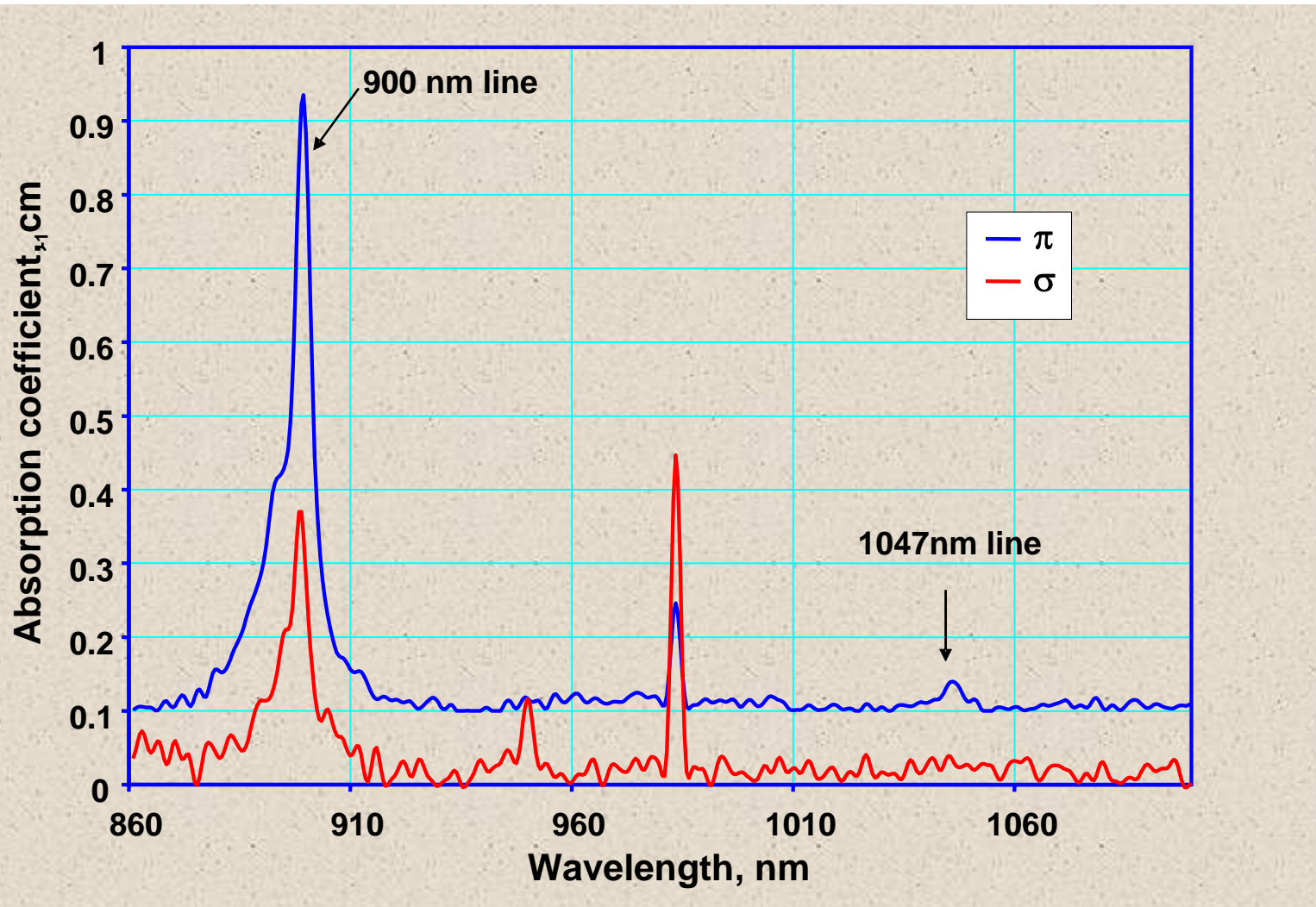

Preliminary Yb:S-FAP results, cw and quasi-CW (100 Hz)

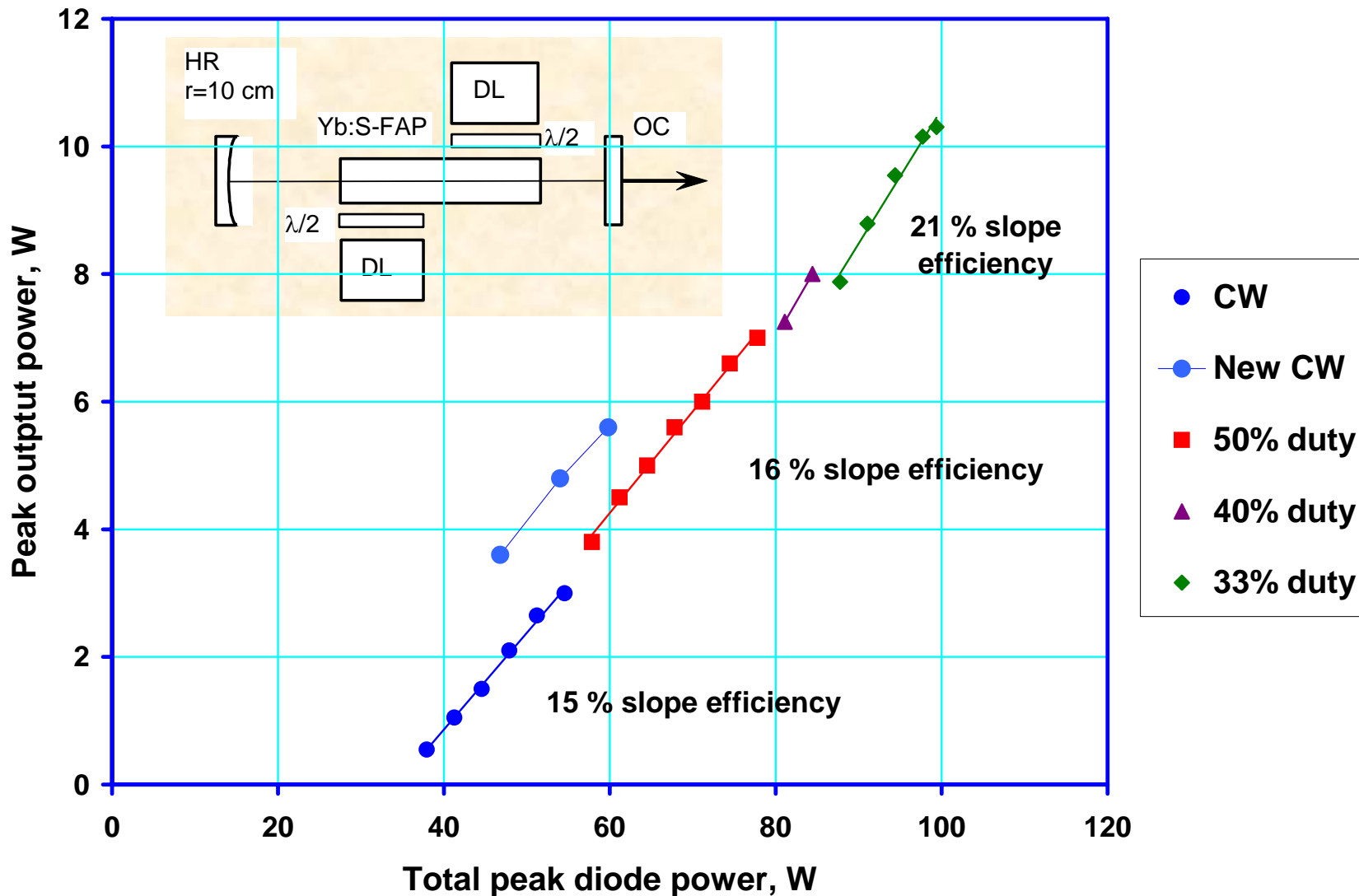

- **The diode-pumped, side-pumped slab design developed for Nd-doped lasers has been extended to other rare-earth dopants**
- **Tm:YLF provides nearly 20 W of cw power in the 2000-nm region, with broad, continuous tunability from 1910-2070 nm**
 - **Applications are in pumping Ho-doped lasers for flash lidar and in remote sensing**
- **Er:YLF provides a unique cw source in the 2800-nm region, and has the potential for line tunability**
 - **Applications are as a surrogate for the HF laser**
- **Yb:S-FAP provides greater energy storage than Nd-doped materials and can be driven by Nd:YLF sources at 1047 nm**
 - **Applications are in moderate-pulse rate, energetic systems such as remote-sensing lidars**