

High-Power, CW-Pumped Nd:YLF Lasers

Peter F. Moulton

1998 Diode Laser Technology Review

Albuquerque, NM

March 2, 1998

SEO  Boston

- **SEO Boston**
 - K. F. Wall
 - K.J. Snell
 - D. Lee
 - M.A. Jaspan
 - Y. Isyanova
 - M. W. Francis
- **USHIO Research Institute of Technology**
 - A. Finch
 - Y. Ohsako
 - J. Sakuma
- **JGM Associates**
 - J.G. Manni

- **Basic system design and performance**
- **Multiple-module systems**
 - **Two-module oscillator**
 - **Single-amplifier MOPA**
 - **Multiple-module MOPAs**
- **Nonlinear conversion results**
 - **Harmonic generation**
 - **Parametric oscillators**

Crystal	Wavelength (nm)	Gain cross section (10-19 cm ²)	Lifetime (μs)	Peak absorption (cm ⁻¹)
YAG	1065	3.3	240	10
YLF (π)	1047	1.9-2.3	480-520	11
YLF (σ)	1053	π / 1.5		
YVO4 (π)	1064	9.8-15.6	97	40

Crystal	Thermal conductivity (W/m K)	Expansion coeff. (10-6)	Thermal shock (W/m)	dn/dT (10-6)	Lensing
YAG	13	6.7	1450	+7.3	moderate
YLF	5.8 (c) 7.2 (a)	8 (c) 13(a)	240	-4.3 (e) -2.0 (o)	weak
YVO4	5.2	7.3 (a) ?? (c)	?	+2.9 (e) +8.5 (o)	strong

- **Advantages**
 - **Weak thermal lensing reduces connection between beam properties and pump power**
 - **Natural birefringence eliminates depolarization from stress-induced birefringence**
 - **Long lifetime maximizes energy in Q-switched pulse**
- **Challenge**
 - **Fracture a greater concern than with YAG**

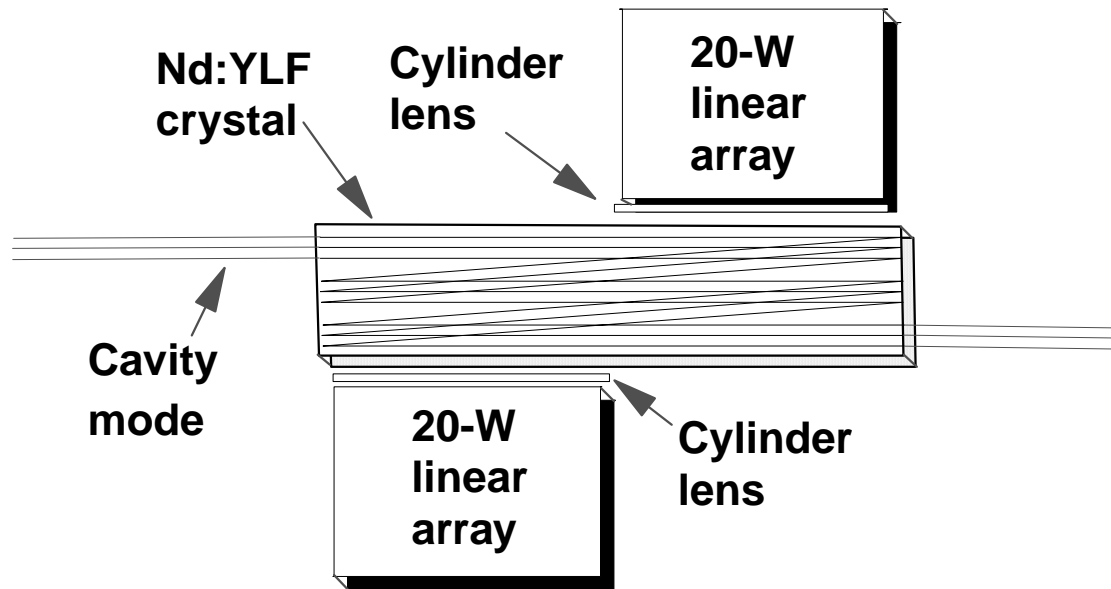

- Multi-pass design extracts large fraction of available power in TEM₀₀ mode, has high gain
- Low average excitation density minimizes stress, beam distortion
- Simple, single-element pump optics

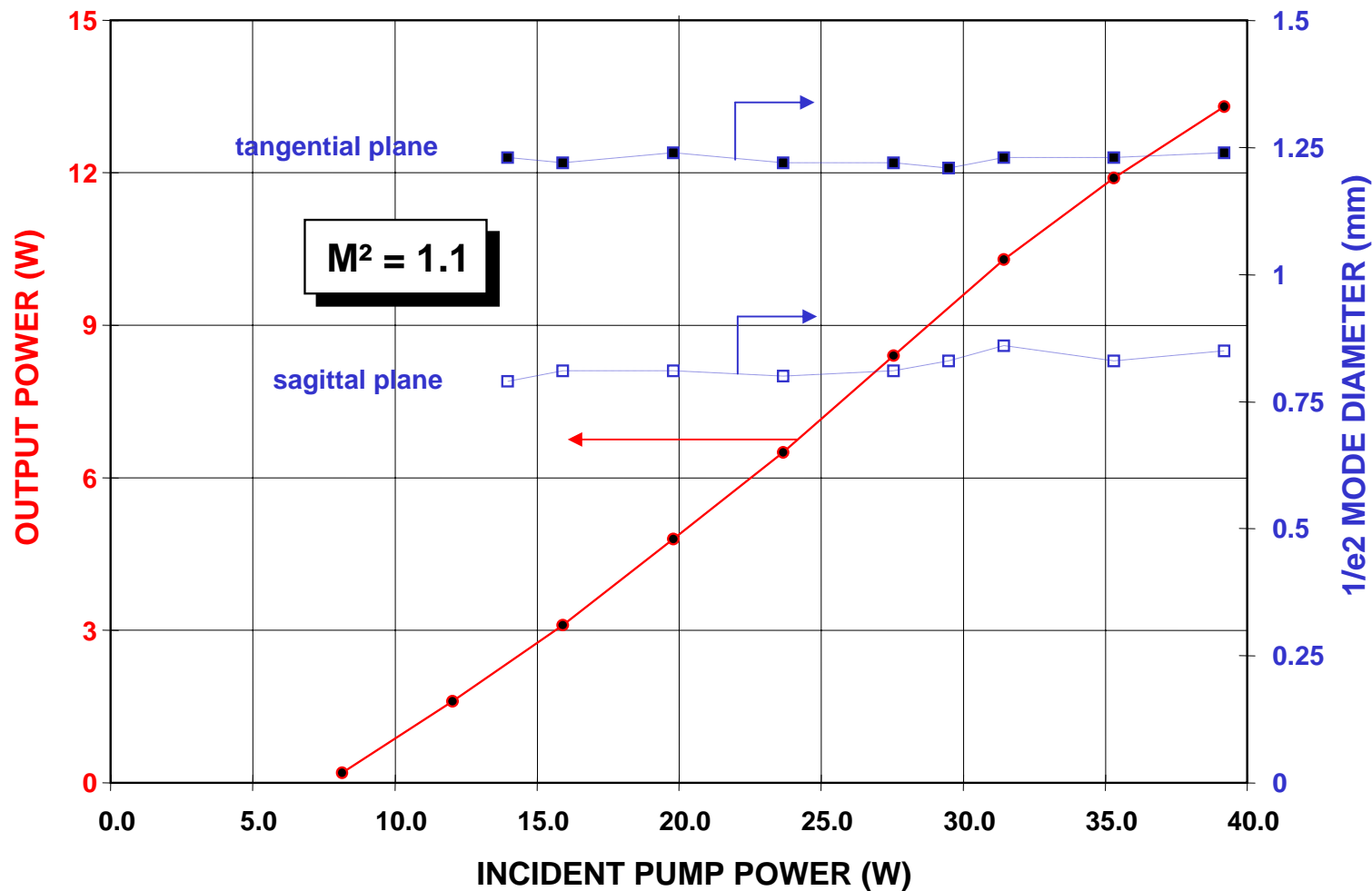

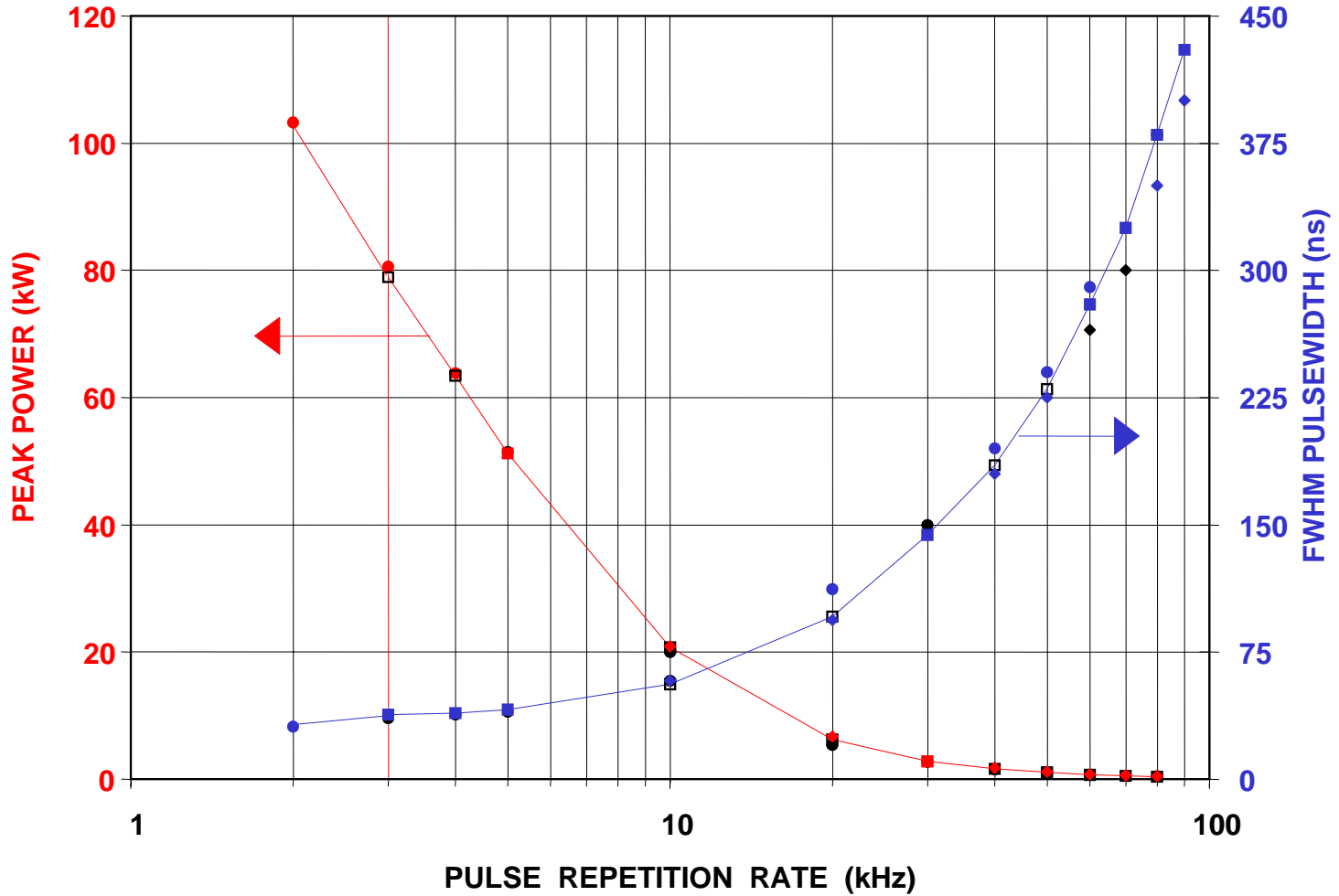

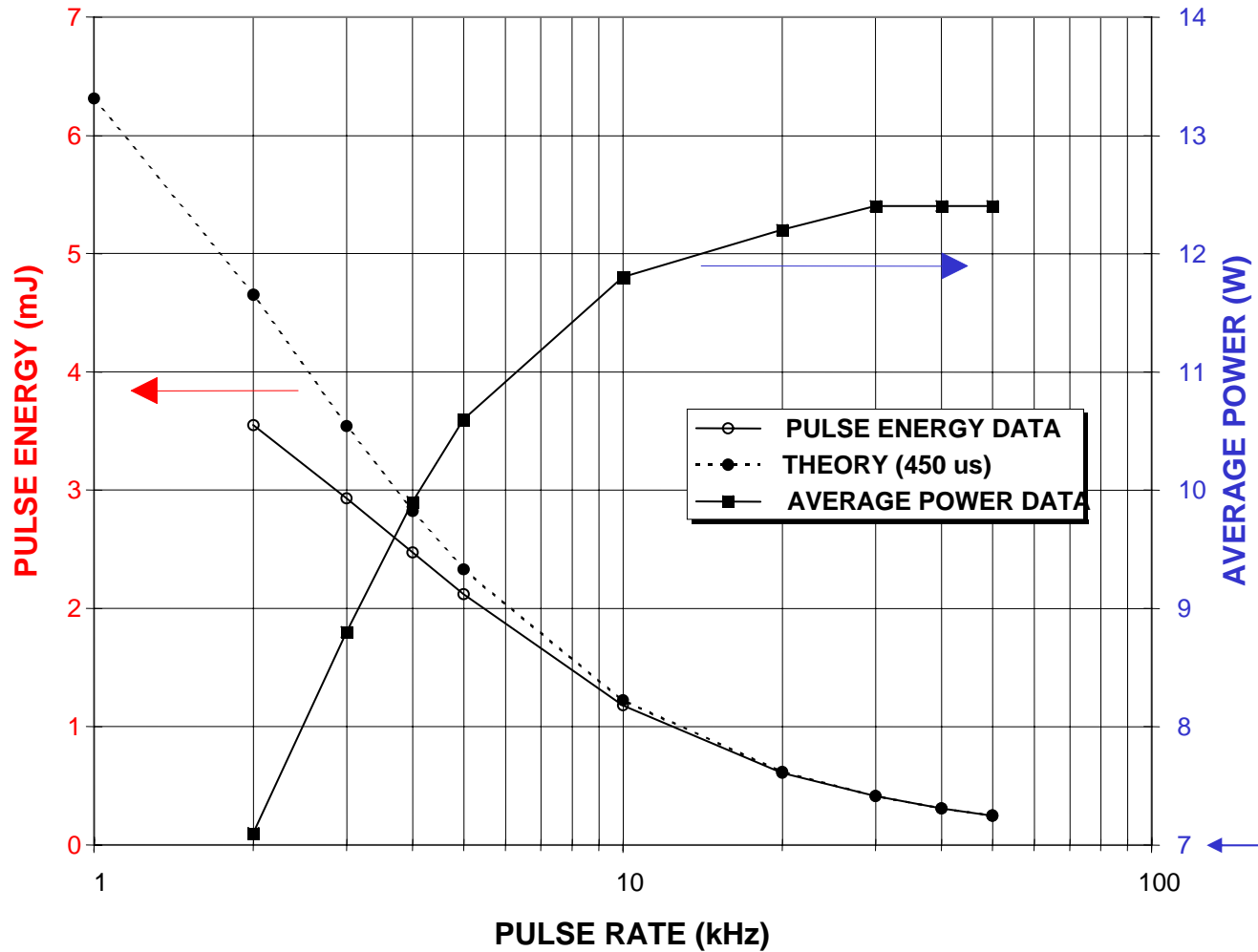

Note!

Two-module oscillator

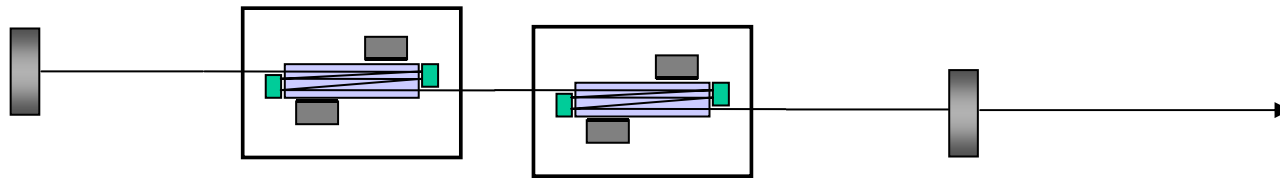

Oscillator-amplifier

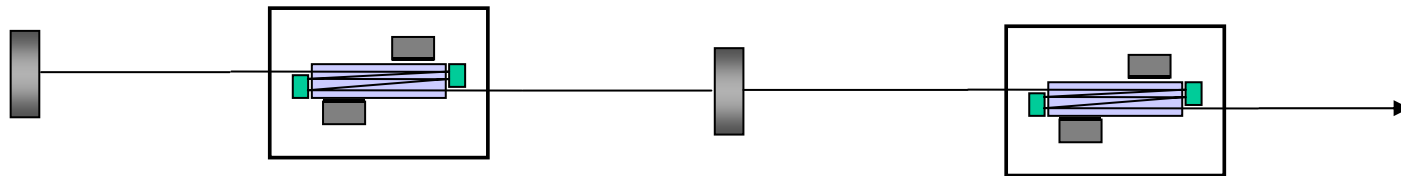

- **Two-module oscillator**
 - 28 W CW power, TEM₀₀
 - 14-ns-duration Q-switched pulses at 5 kHz
 - EO Q-switch

- **Oscillator-amplifier**
 - 25 W CW power (with isolator), TEM₀₀
 - 19 W Q-switched average power at 5 kHz, 20-ns pulses
 - Small signal gain of 4
 - >30% extraction of cw pump power

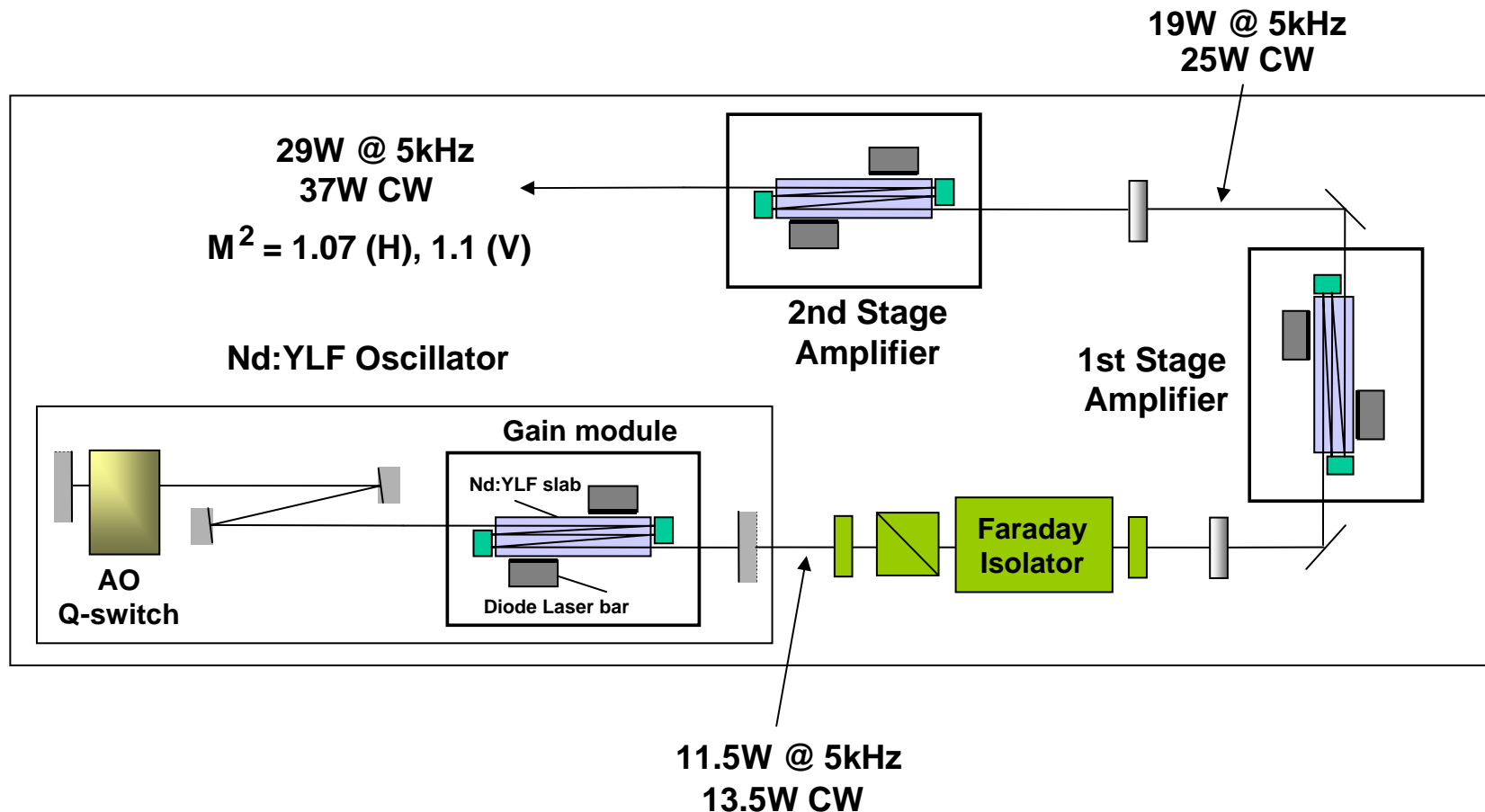

OUTPUT OF SECOND AMPLIFIER vs DIODE DRIVE CURRENT, MOPA #1

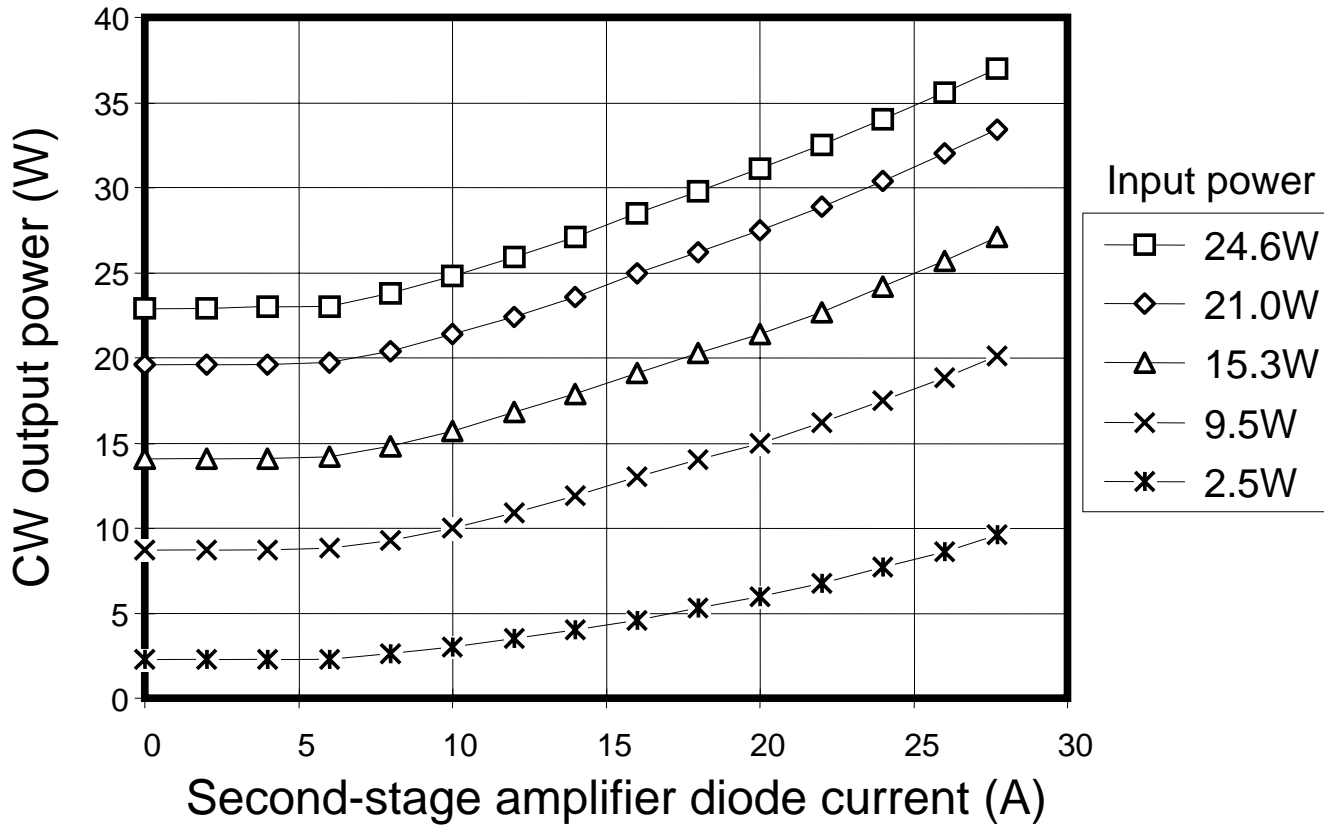

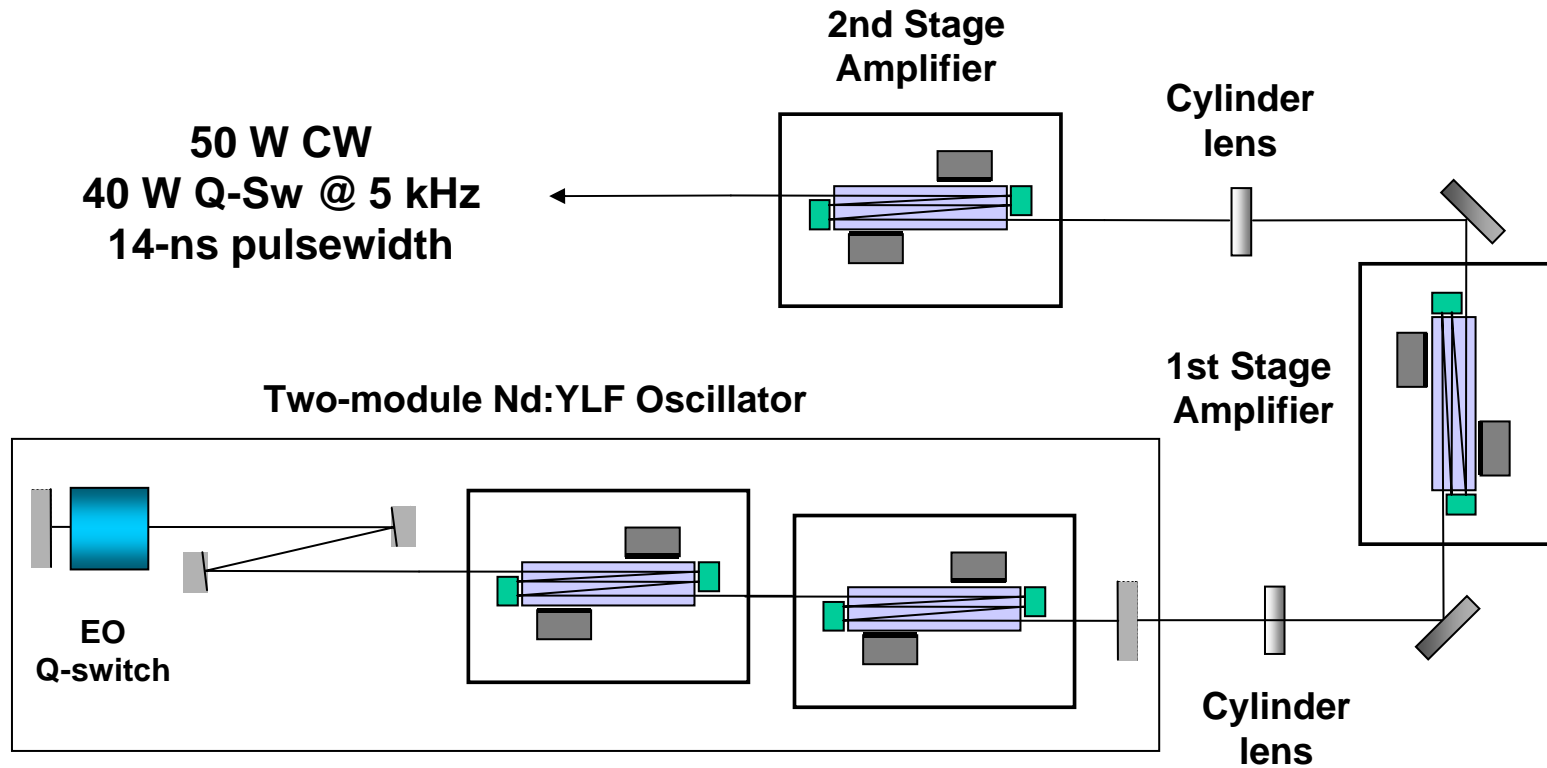

24-Feb-98

11:15:54

LE no
8547

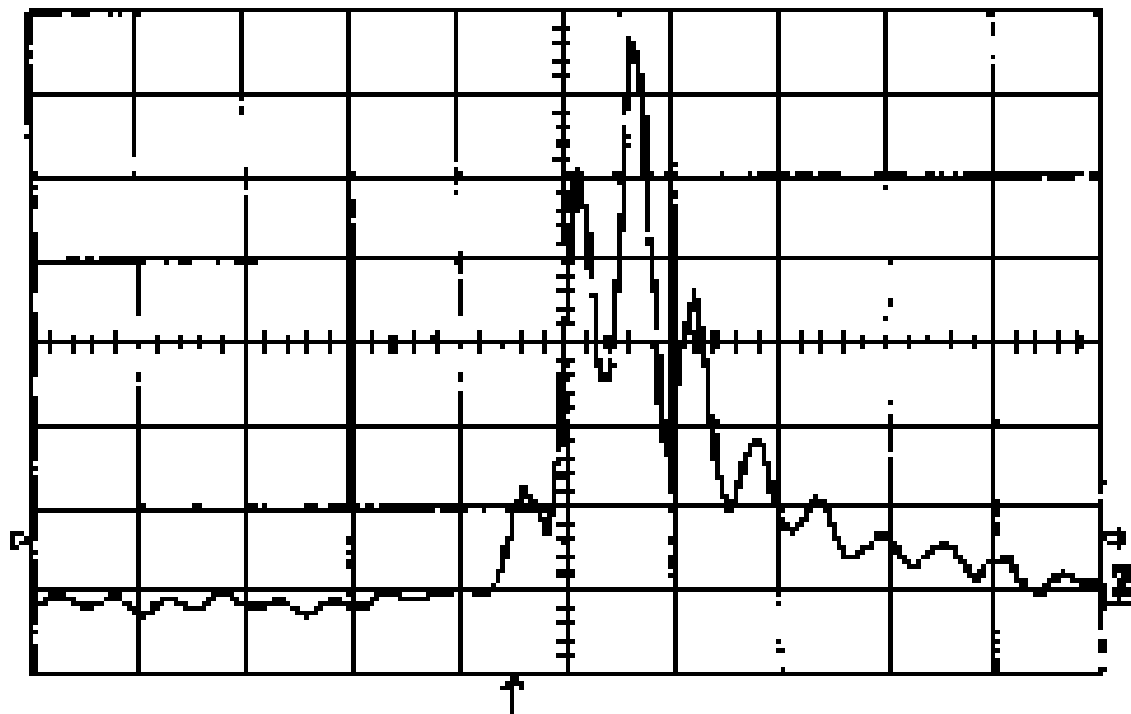

10 ns per division

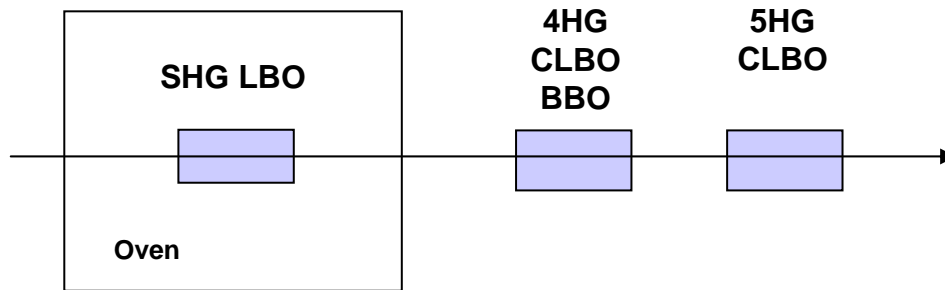

Best results:

**SHG: 14 W at 5 kHz
and 65% conversion
in LBO**

**4HG: 6.6 W (internal)
at 5 kHz with CLBO
2.5 W at 10 kHz in BBO**

**5HG: 2 W (internal)
at 5 kHz with CLBO**

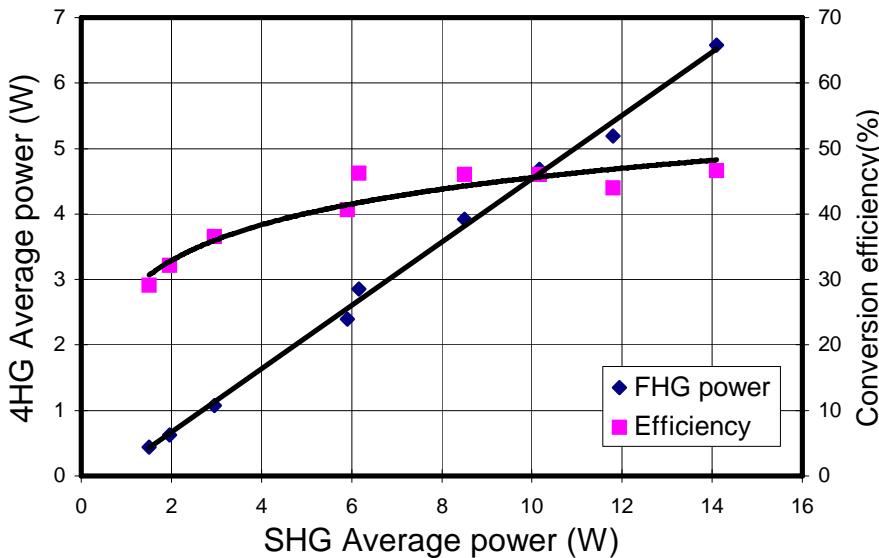

Intracavity OPO

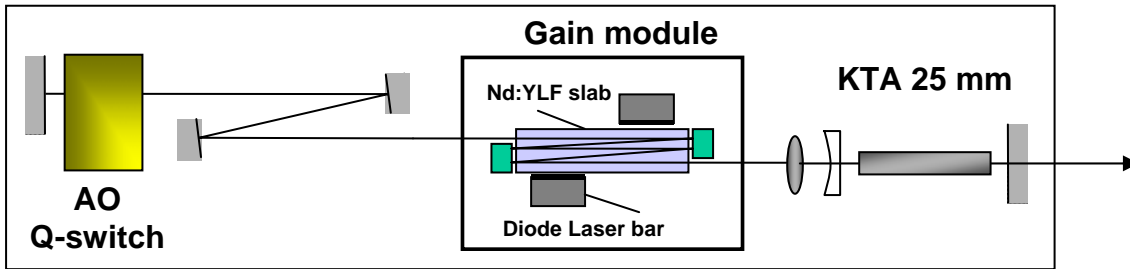

**1 W output
at 1507 nm
12.5 kHz PRR
6 ns pulsewidth**

External OPO

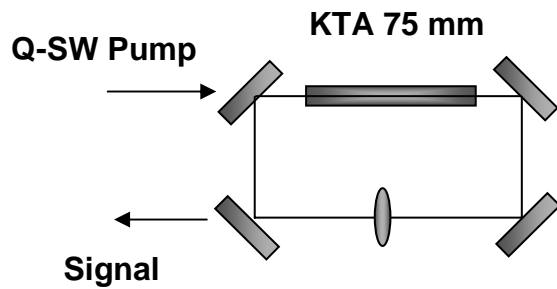

43% conversion to 1507 nm

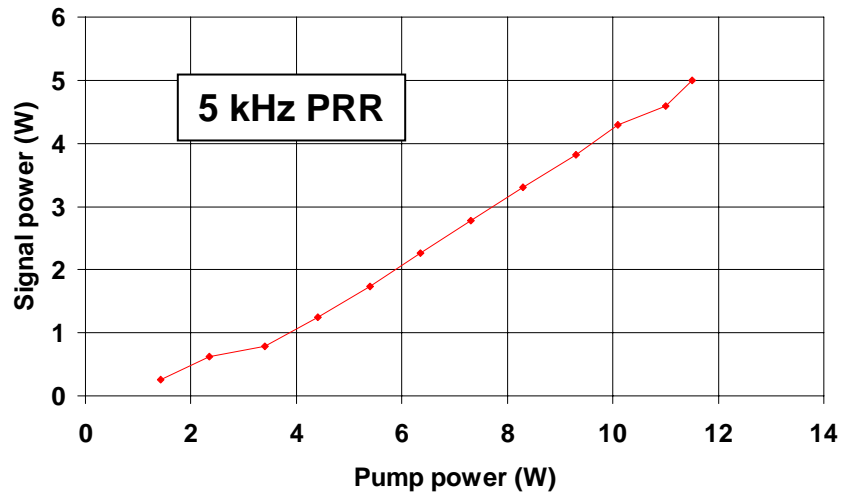

- **Pump source: MOPA #2**
- **KTA OPO**
 - **60-mm crystal length, 80-degree cut**
 - 30 W pump, 5 kHz PRR
 - 10 W at 1530 nm, 3 W at 3340 nm
 - **40-mm crystal length, 60-degree cut**
 - 15 W pump, 5 kHz PRR
 - 1 W of idler tunable from 2500-2900 nm
- **PPLN OPO**
 - **19-mm crystal length, 30.8-um pitch**
 - 30 W pump, 5 kHz PRR
 - 5.2 W at 2610-nm idler, 3W at 1720-nm signal

- **Basic Nd:YLF design can be scaled to higher powers with same efficiency as a “single-module” system, and with minimal thermo-optic distortion**
- **Demonstrated 50 W CW from four modules, with TEM₀₀ output, the highest-power cw diode-pumped Nd:YLF laser to our knowledge**
- **Efficient nonlinear conversion has been demonstrated at 5-kHz rates, with record UV powers**
- **Further scaling will be possible with more modules and/or higher-power bars**