

Laser-Diode-Pumped Solid State Lasers

Peter F. Moulton

Q-Peak, Inc.

Bedford, MA

CNOM Program

7th Annual Affiliates Meeting

Stanford University

September 25, 1999



- **Introduction to Q-Peak**
- **Description of MPS Nd:YLF laser system**
 - Basic design of gain module
 - Performance of module
- **Description of MPV Nd:YVO₄ laser system**
 - Performance of module
- **Scaling to higher powers**
- **Harmonic generation**
- **Parametric generation**



What is Q-Peak???

**Research Division of Schwartz
Electro-Optics, Inc. (1985)**



SEO Boston (name change, 1997)



**Q-Peak, Inc. (wholly owned
subsidiary, 1998)**



Three Nd Laser Hosts As Choices

Crystal	Wavelength (nm)	Gain cross section (10-19 cm ²)	Lifetime (μs)	Peak absorption (cm ⁻¹)
YAG	1065	3.3	240	10
YLF (π)	1047	1.9-2.3	480-520	11
YLF (σ)	1053	π / 1.5		
YVO4 (π)	1064	9.8-15.6	97	40

Crystal	Thermal conductivity (W/m K)	Expansion coeff. (10-6)	Thermal shock (W/m)	dn/dT (10-6)	Lensing
YAG	13	6.7	1450	+7.3	moderate
YLF	5.8 (c) 7.2 (a)	8 (c) 13(a)	240	-4.3 (e) -2.0 (o)	weak
YVO4	5.2	7.3 (a) ?? (c)	?	+2.9 (e) +8.5 (o)	strong

MPS Pumping Design

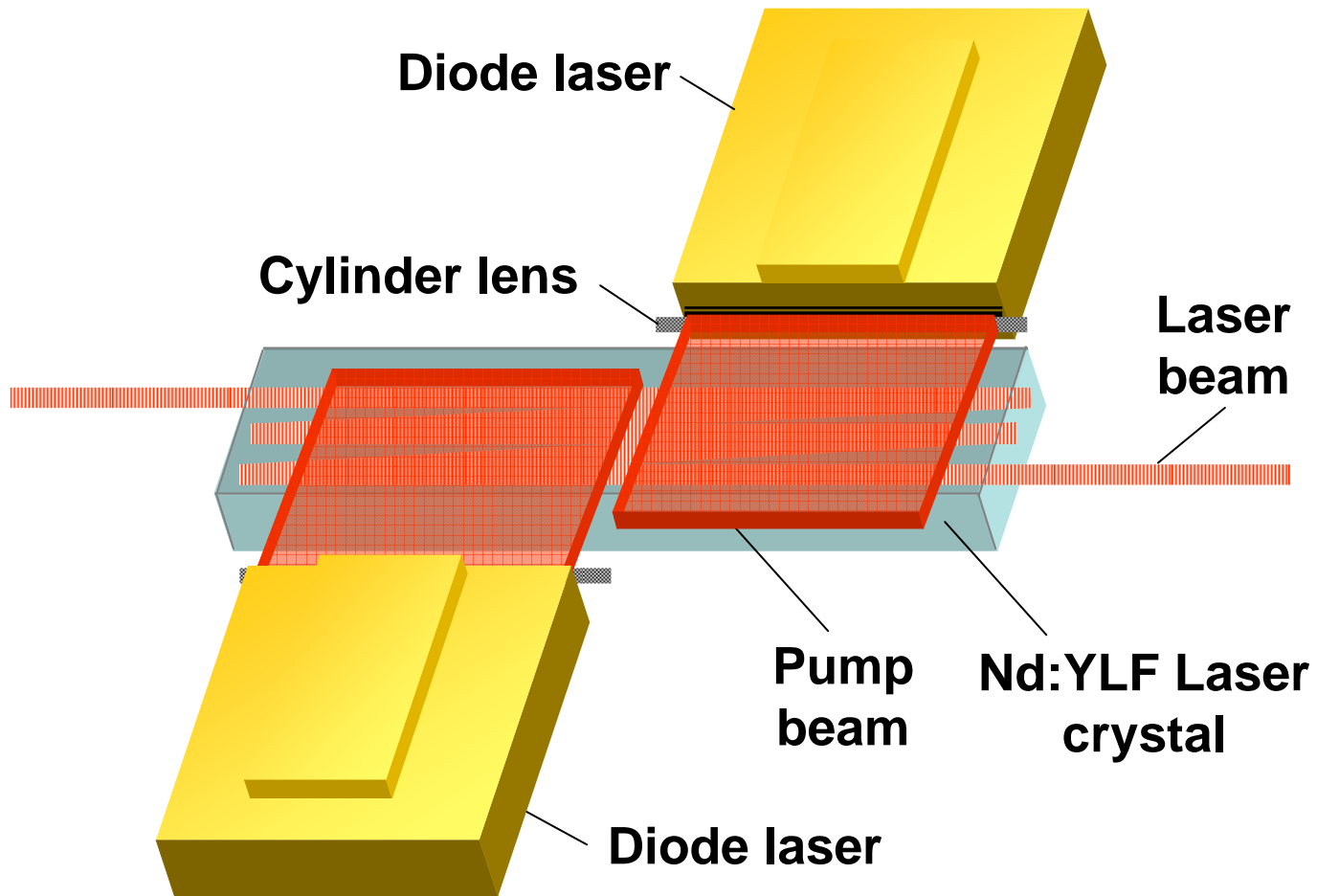

MPS gain module with resonator (MPS-1047)

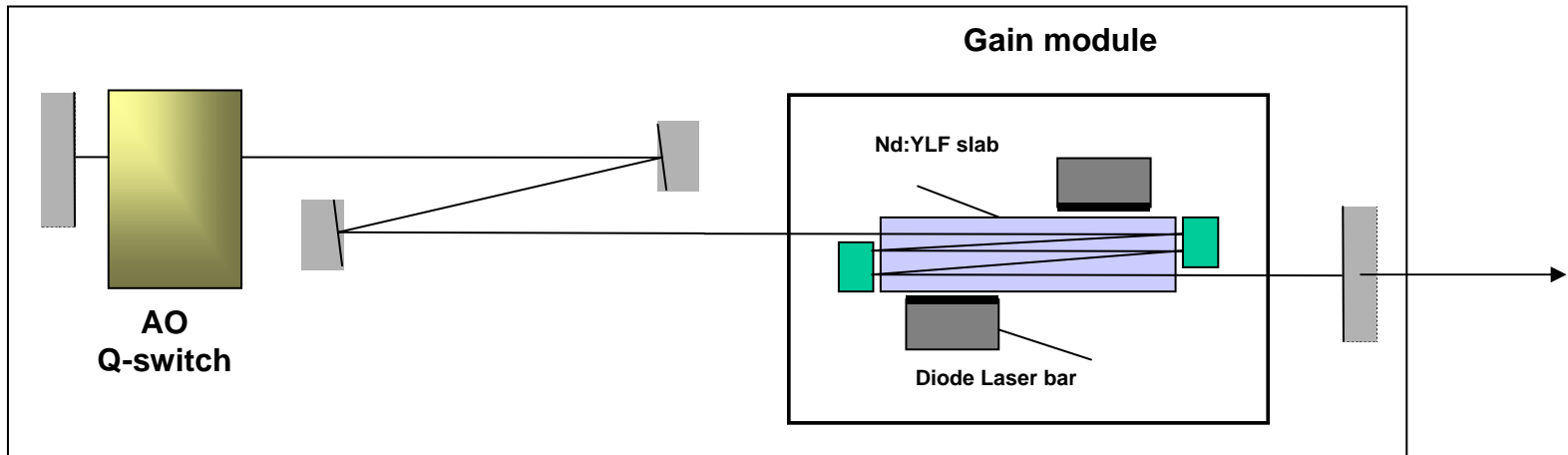

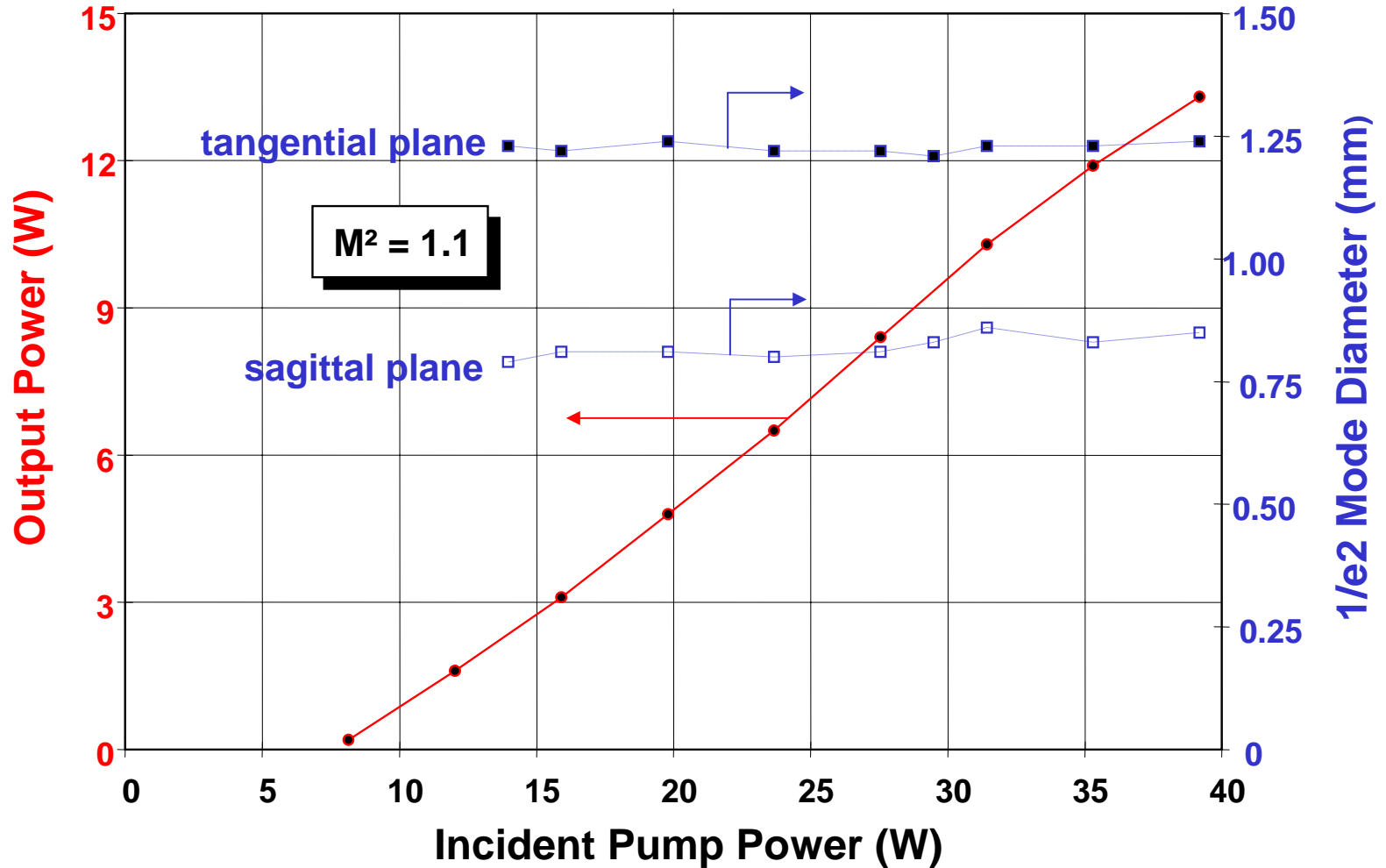



Pointing Stability Over 1 hr is $\pm 2 \mu\text{rad}$

Dsse / Knife Edge 05.12
Total 86.47% 78478
Peak 0 206
Pk Loc 810.00, 837.00
Center 819.71, 829.41
Diameter 385.37 μm
X,Y 387.27, 428.51

Elliptical
Orientation ...
Roundness

Point Stability 8809
Total, Avg 78866
Dev 1252
Min 43543
Max 73167

Center 812.11, 833.58
Dev 3.45, 4.06
Min 799.88, 817.49
Max 823.32, 849.92

Diam 381.97, 2.38
374.69, 392.83

X,Y 376.16, 422.46
Dev 5.63, 1.55
Min 361.83, 414.46
Max 415.13, 435.52

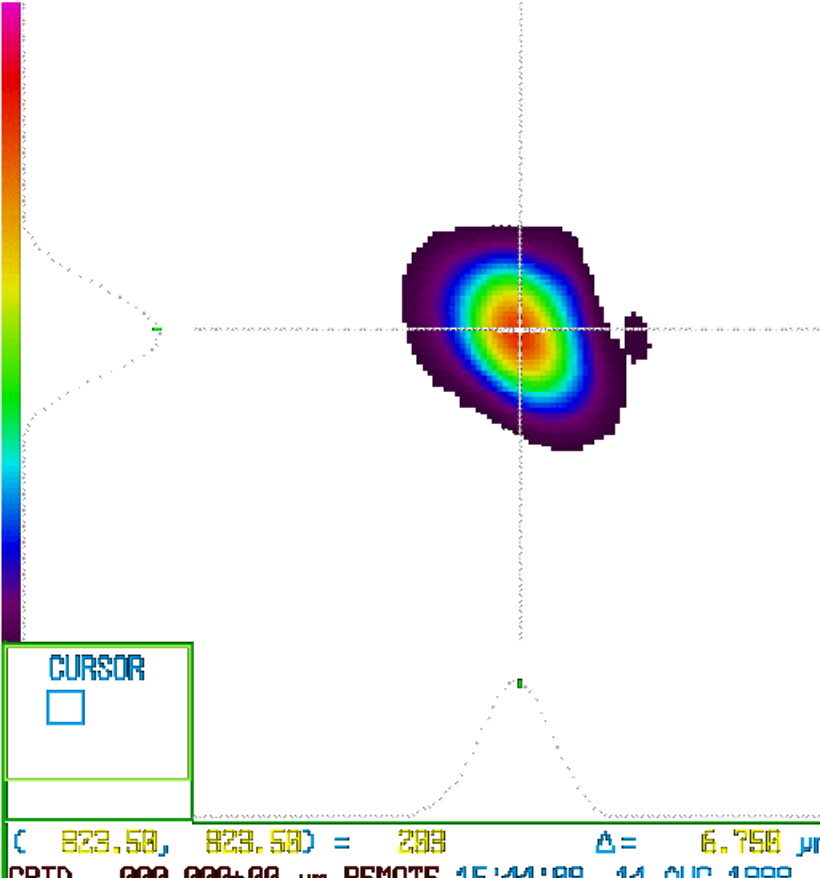

Near Field mrad
(c)1995 Spiricon, Inc.

GRID 000.000+00 μm REMOTE 15:44:09 14 AUG 1998
*SPIRICON 29 CONT CW -REF AUG STOPPED
CALIBRATED GAIN 0 BLACK 128

MPS-1047 Laser System photo





Production data on MPS gain module

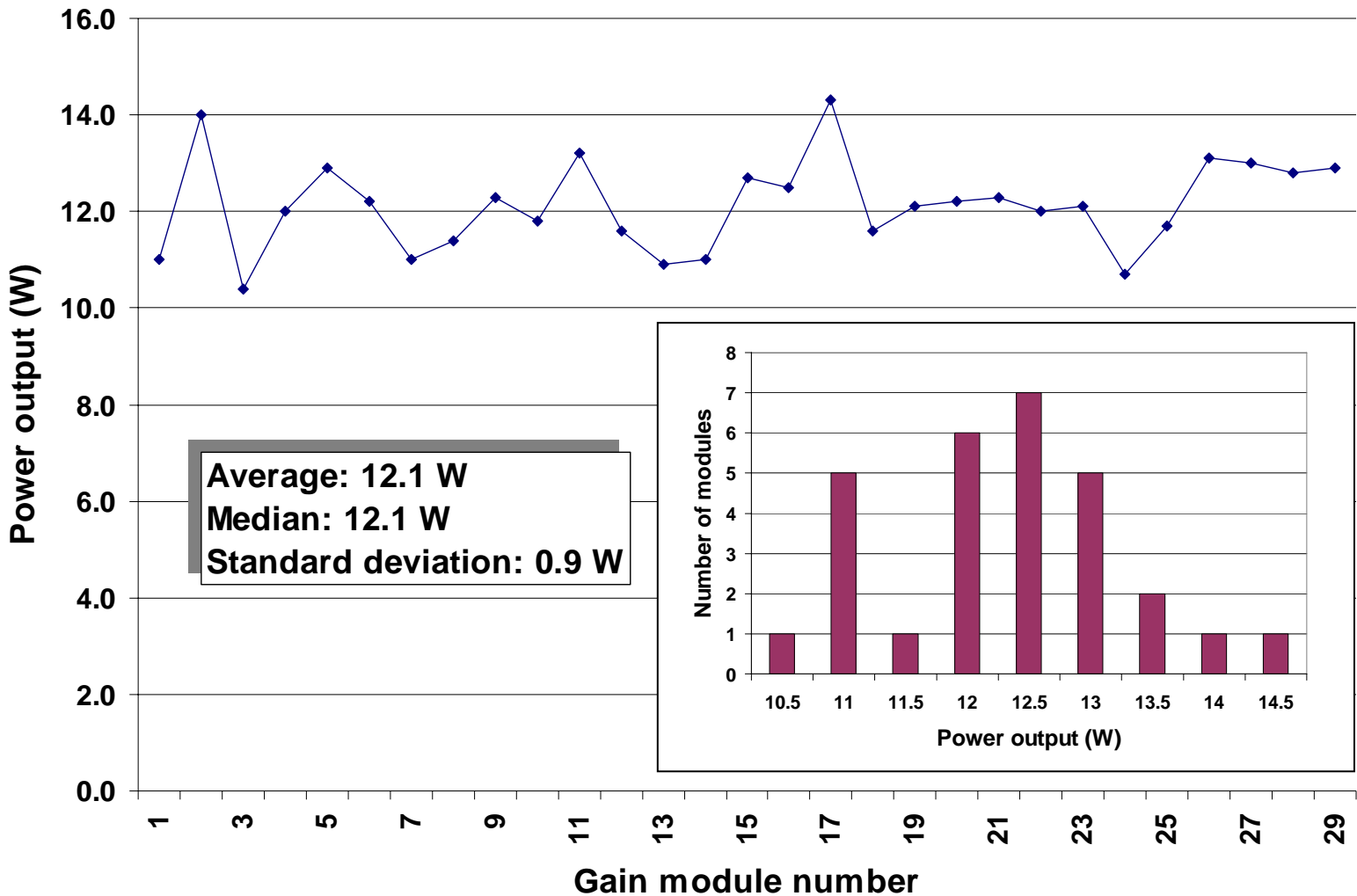

High-power, MPV (Nd:YVO₄) gain module

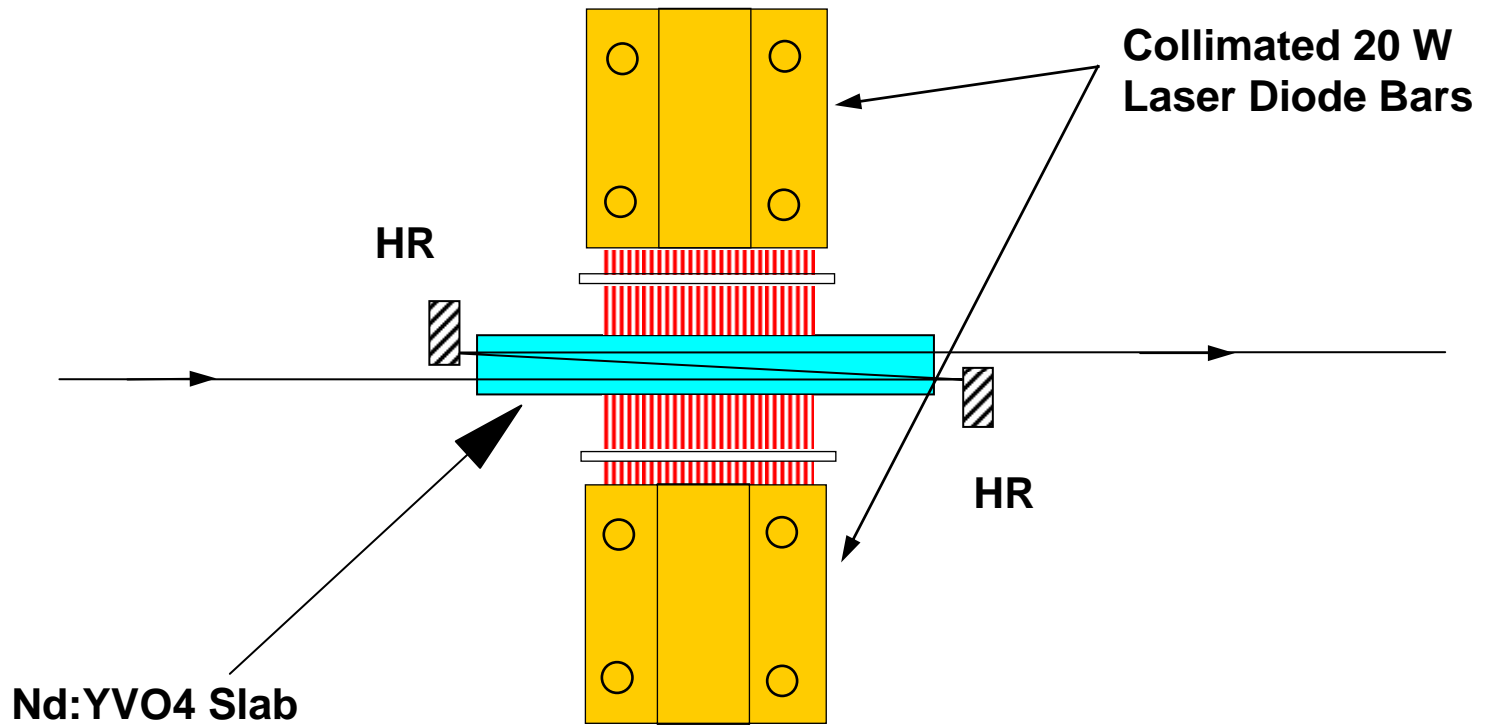

MPV (Nd:YVO₄) Oscillator CW Efficiency

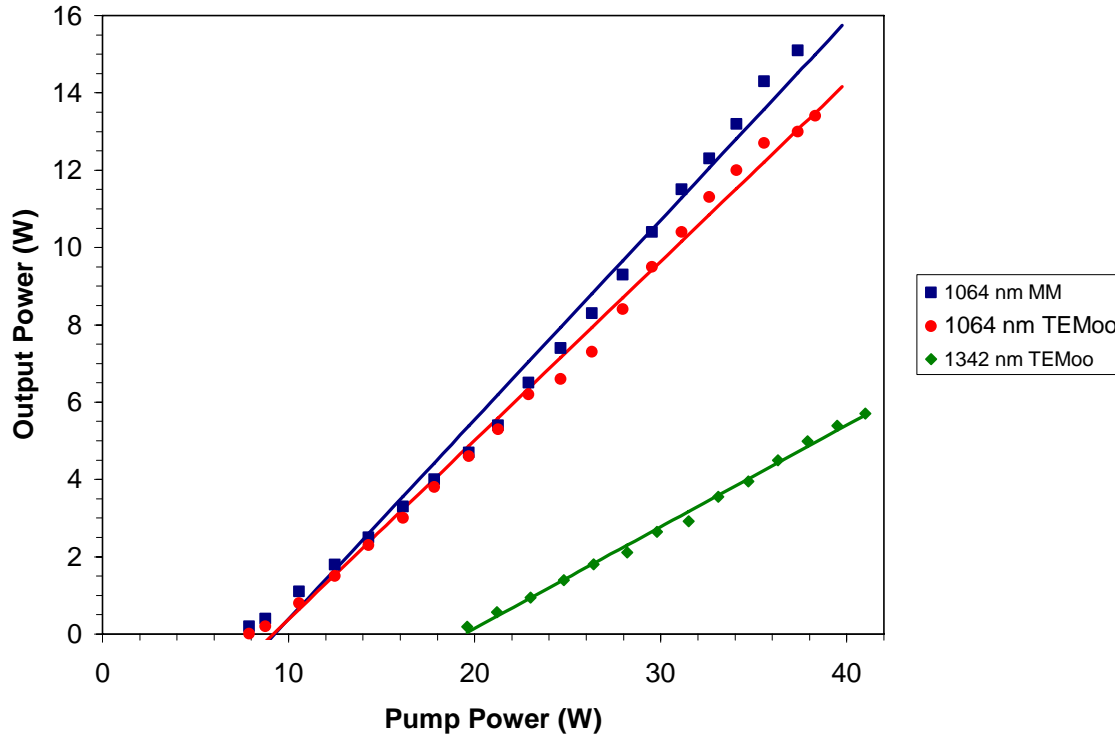

- **1064 nm, >15 W multimode, >13 W TEM₀₀, 46.3% slope, 35.0% optical and 13% electrical efficiency.**
- **1342 nm, >6 W TEM₀₀, 26% slope, 15% optical and 6% electrical efficiency.**

Nd:YVO₄ Slab CW Amplifier Performance

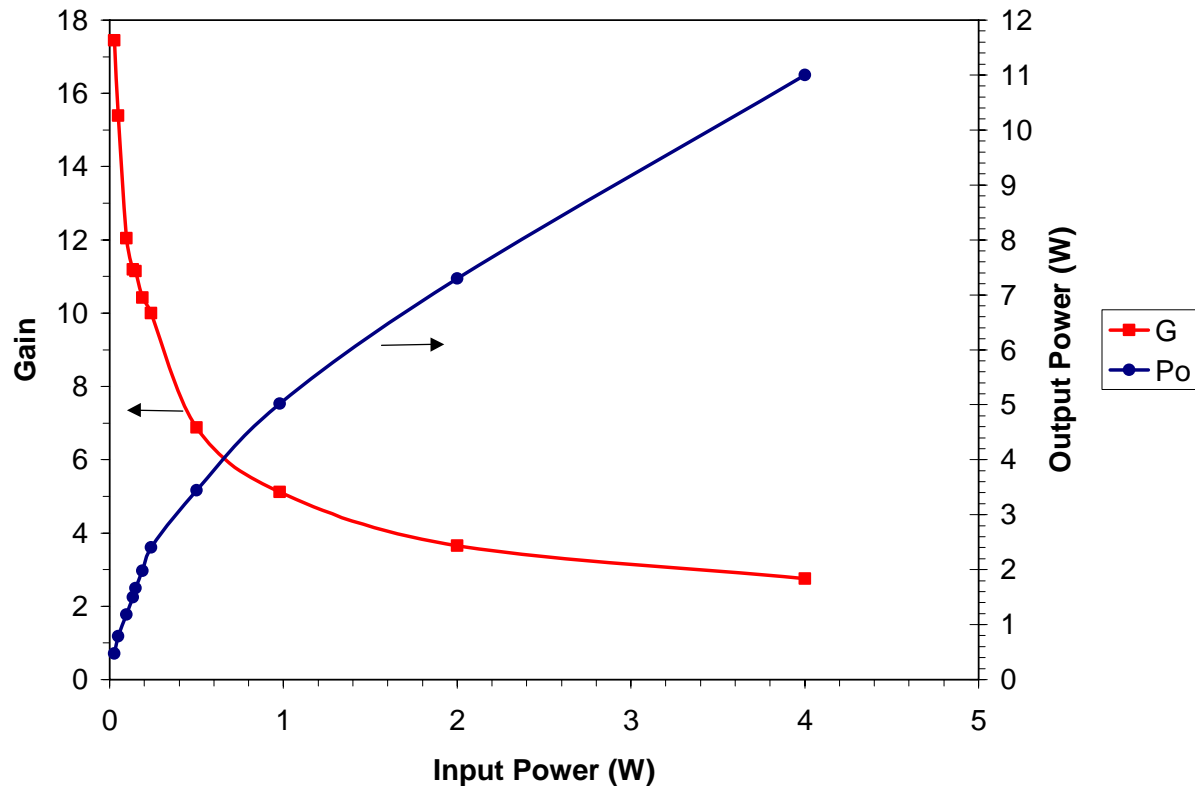

- **Gain of 17 with 27 mW input at a pump power of 38.7 W. 3-pass small signal gain of 24 based on single-pass measurements.**



MPS (Nd:YLF) and MPV (Nd:YVO4) pulse energy vs. rate

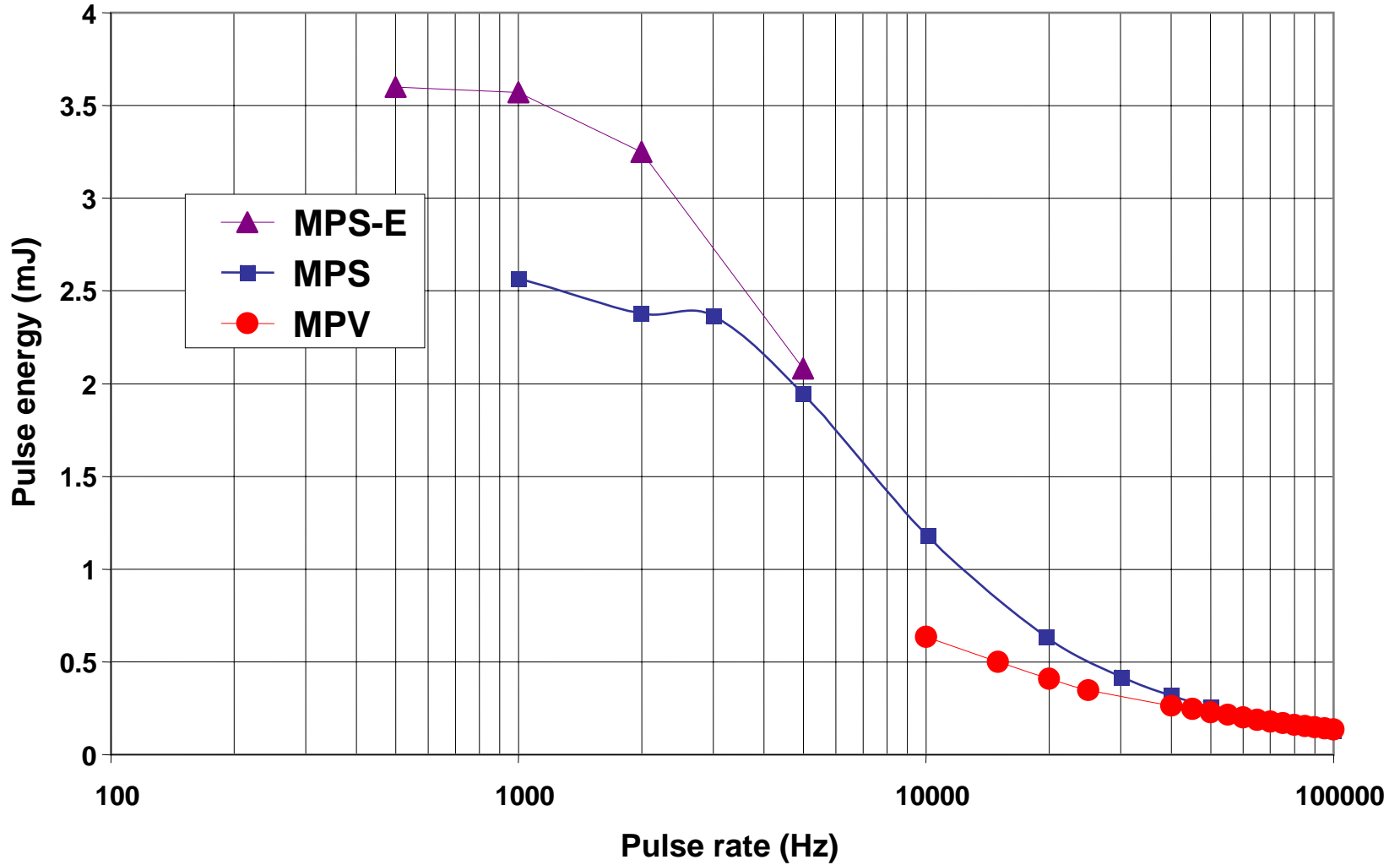



MPS and MPV pulsewidth vs. rate

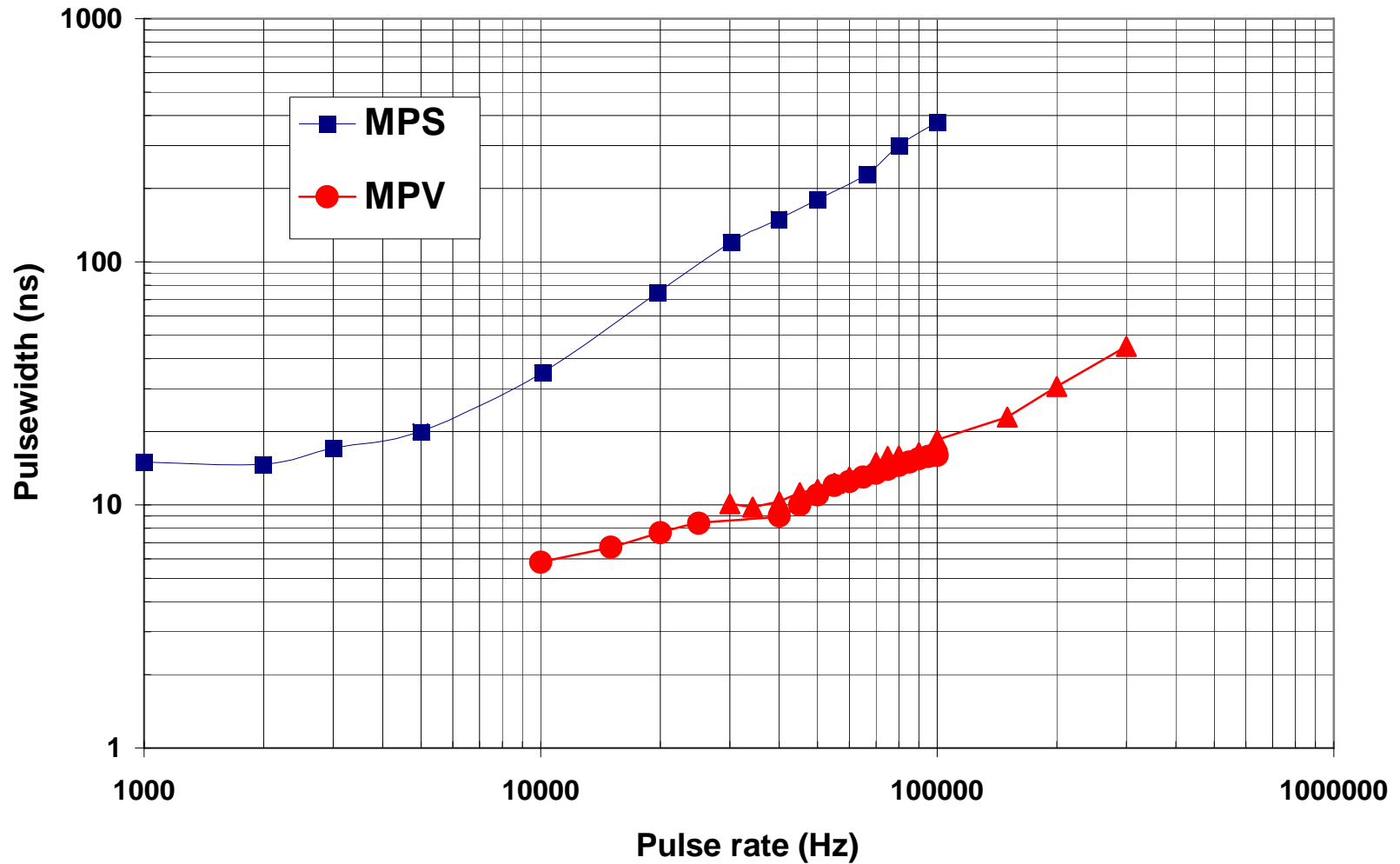



MPS and MPV peak power vs. pulse rate

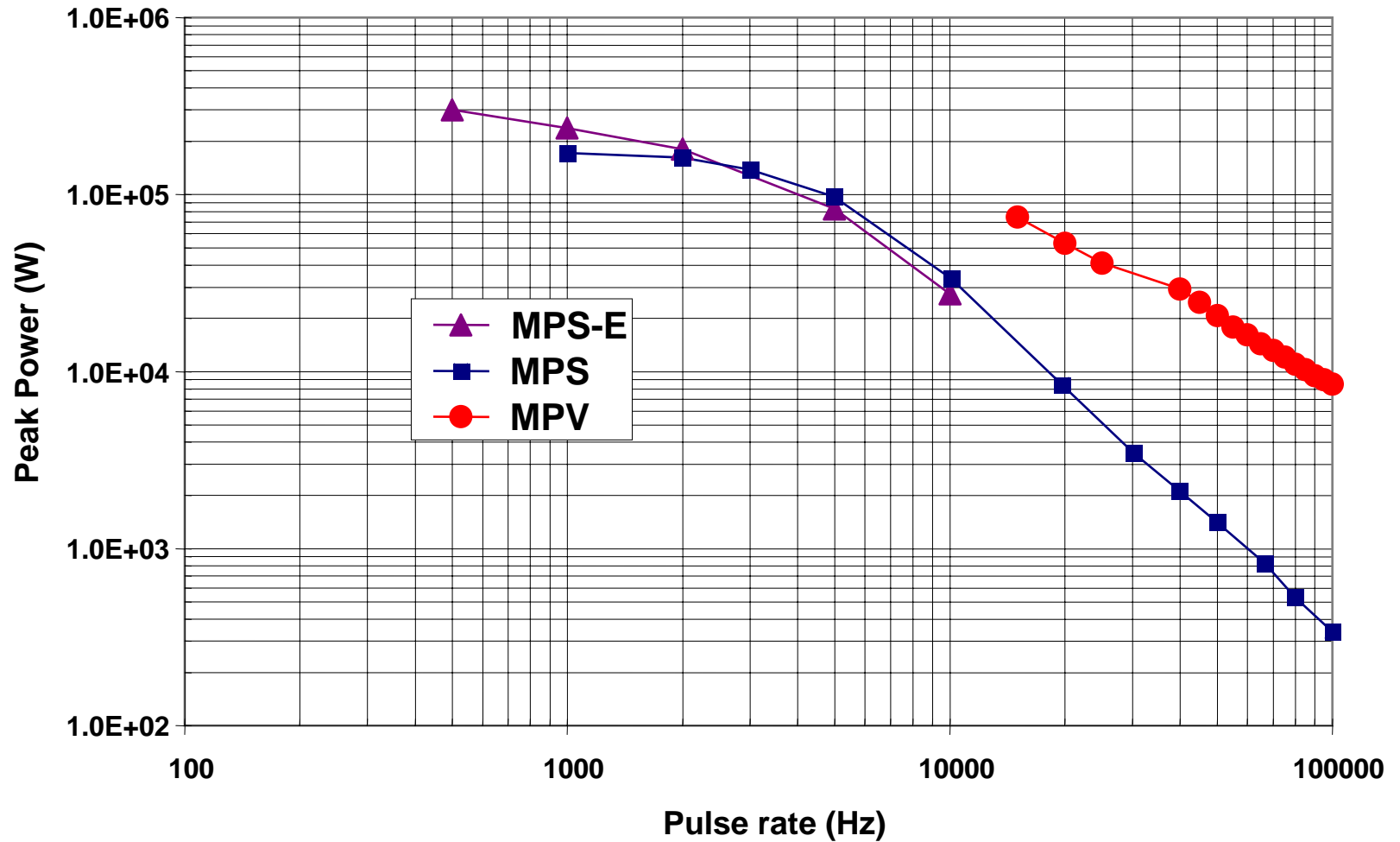



1342 nm Nd:YVO₄ Oscillator Q-Switched Performance

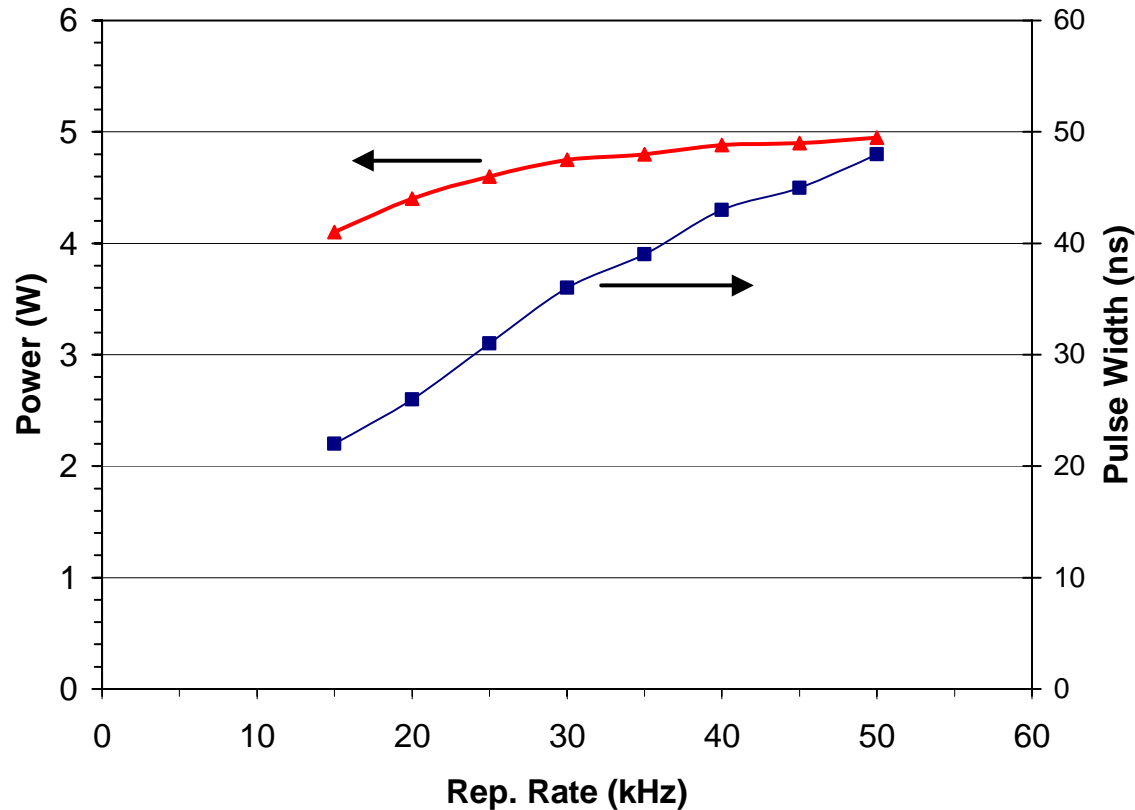

- **>5.0 W Average power @ 25 kHz (0.2 mJ/pulse), < 28 ns pulse width (7.1 kW peak).**



MPS MOPA system #1 generates 37 W cw

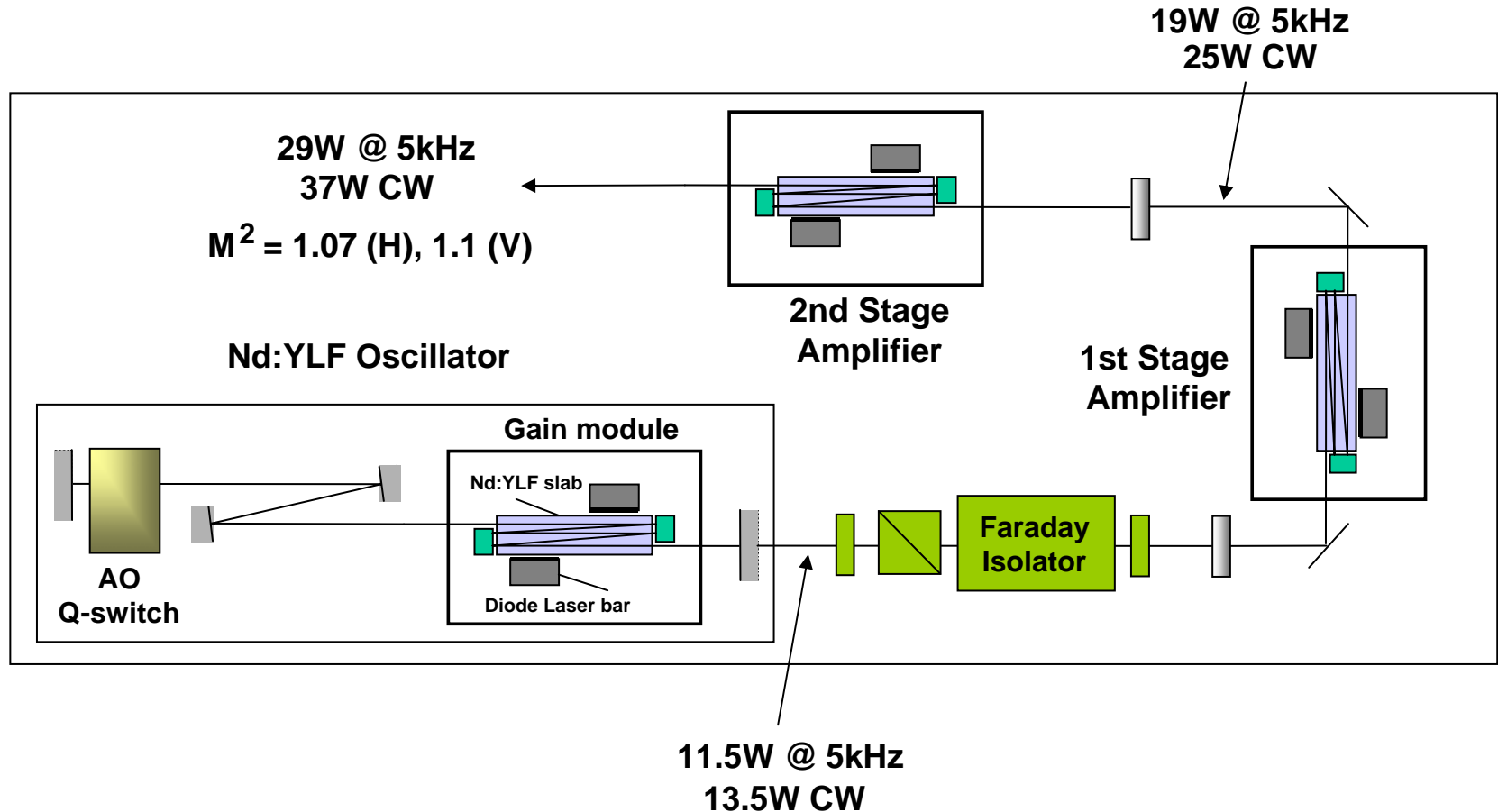



MPS MOPA system #2 generates 50 W cw

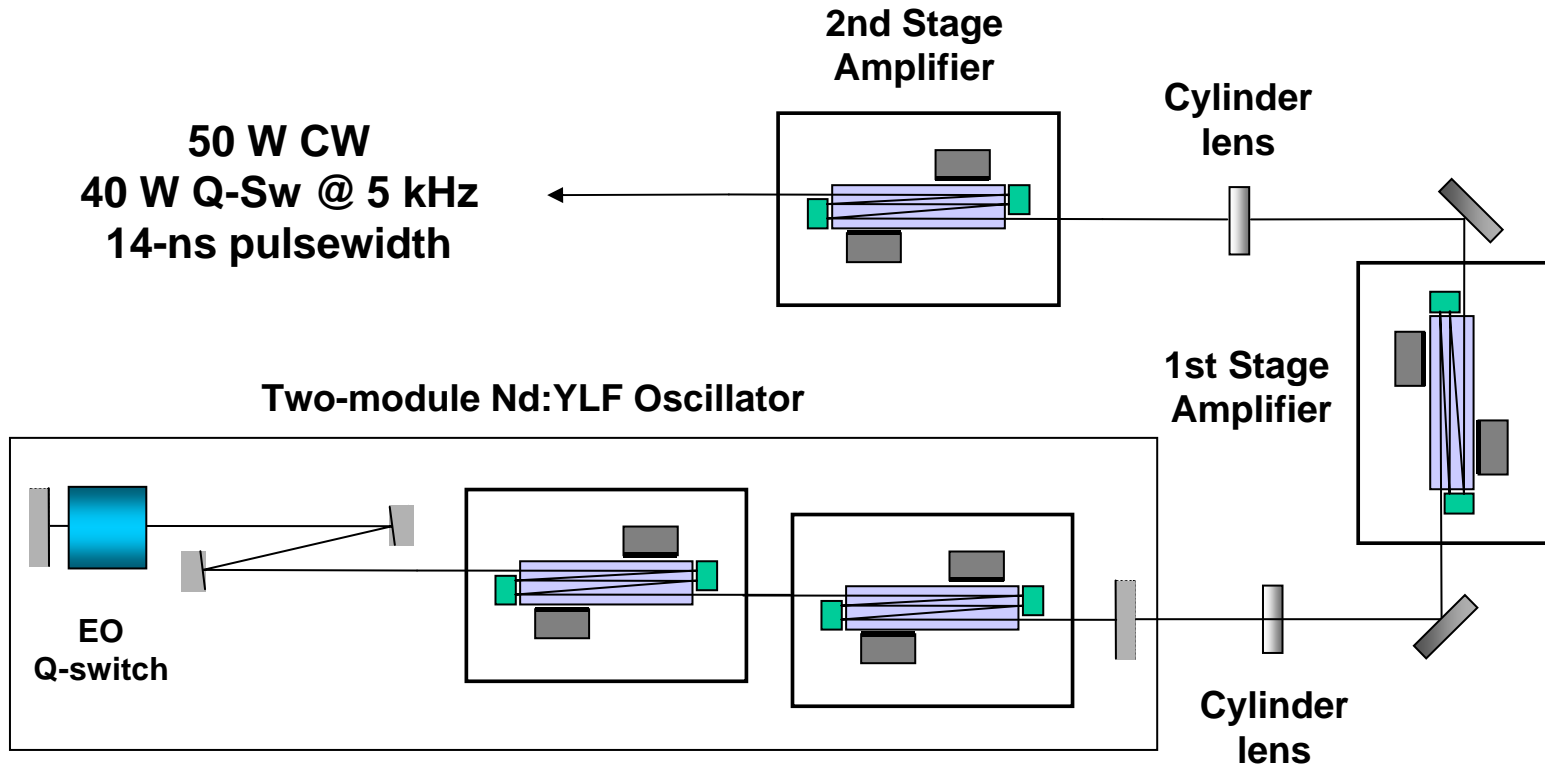

MOPA #2 laser head

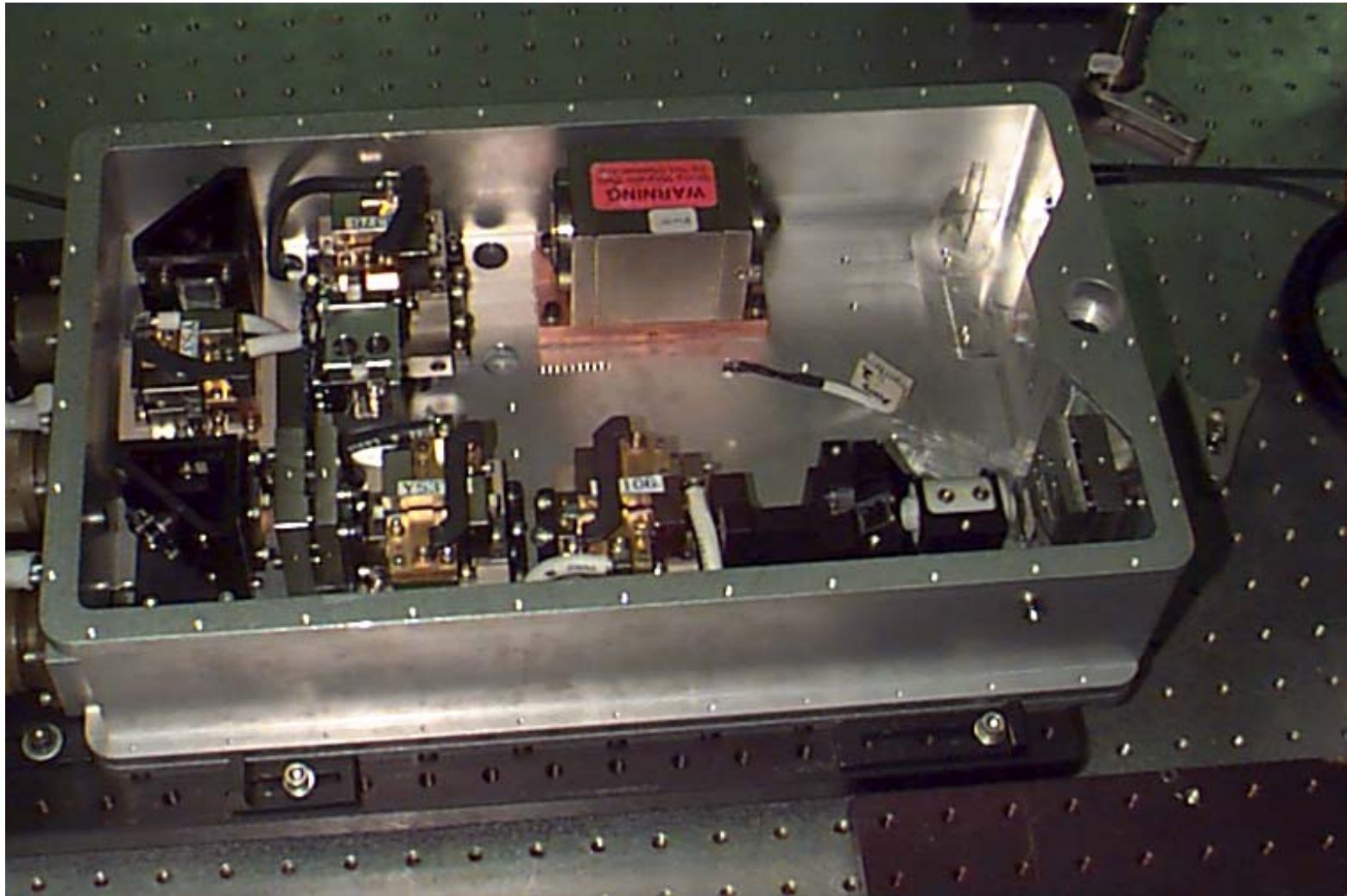



MPS MOPA Design #3; Single Gain Module Oscillator, Four Amplifiers

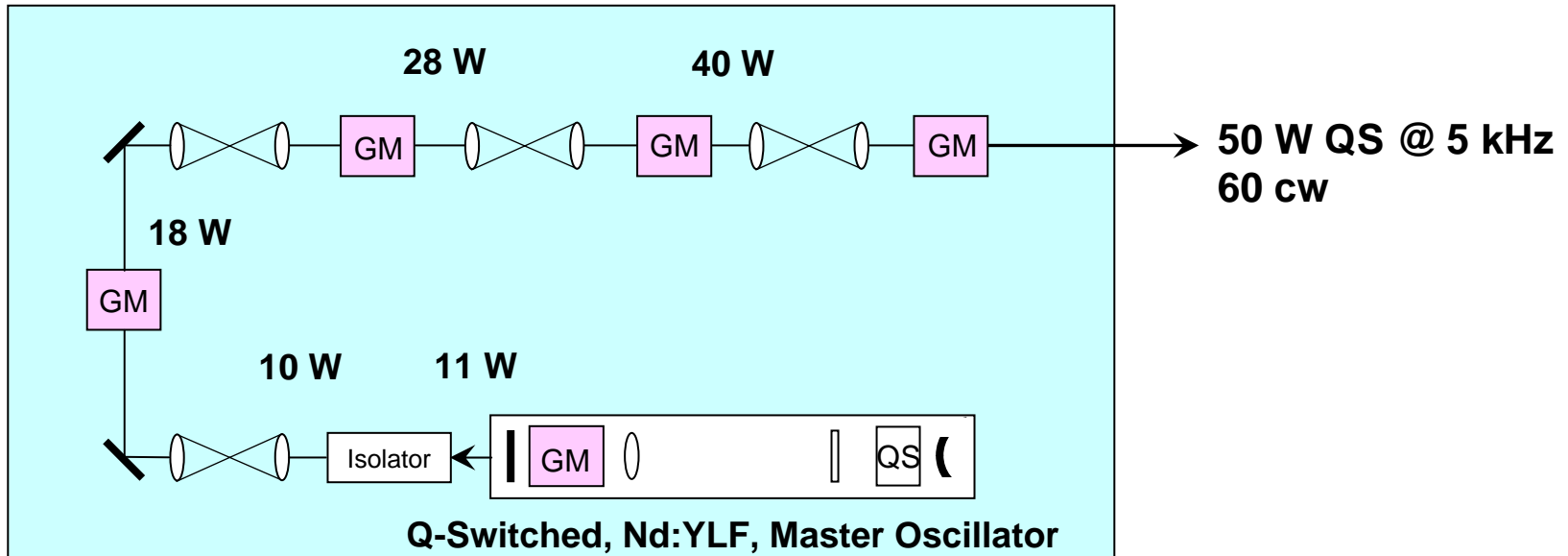

Relay Optics



Gain Module



Mirrors



AO Q Switch

MPS MOPA #4: Single Frequency Oscillator Schematic

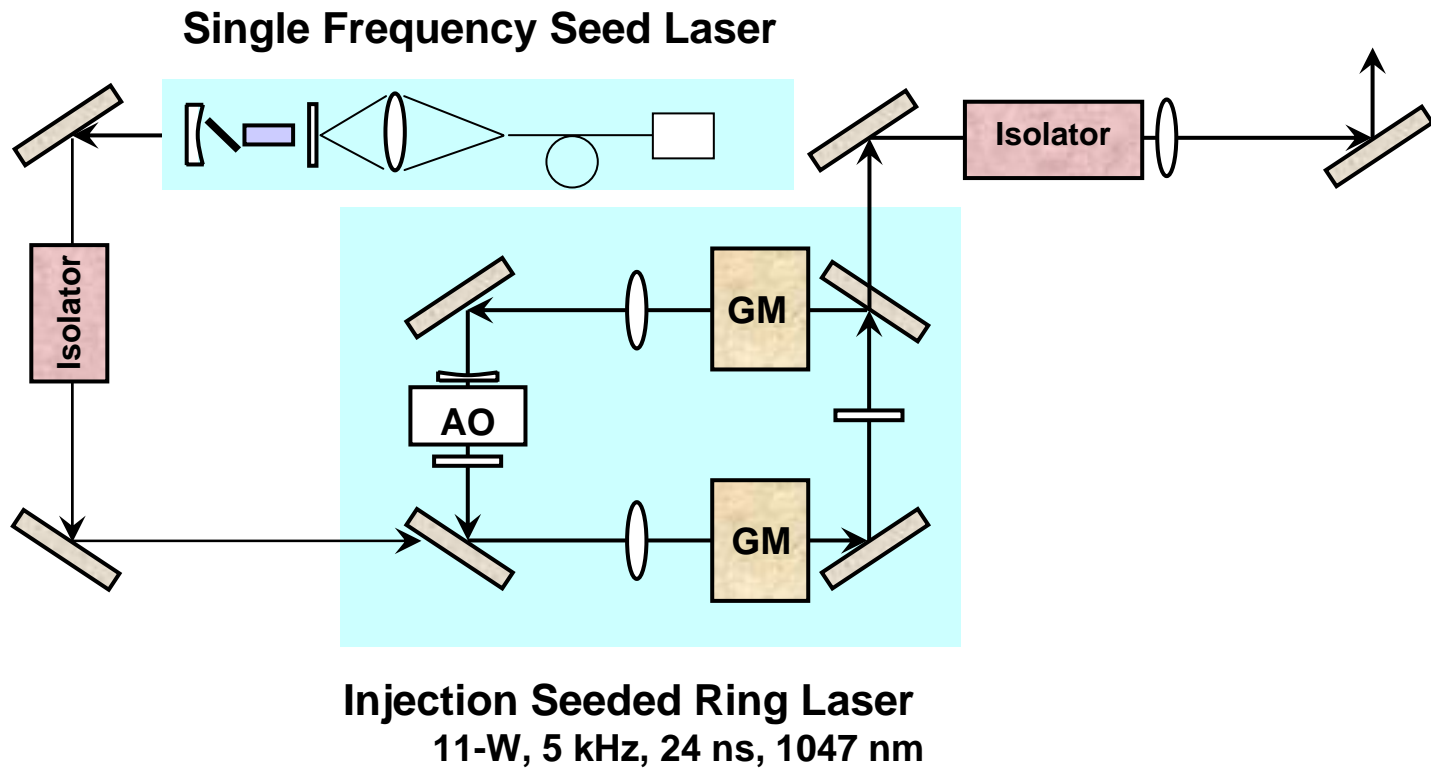

MOPA #4: Amplifier stages

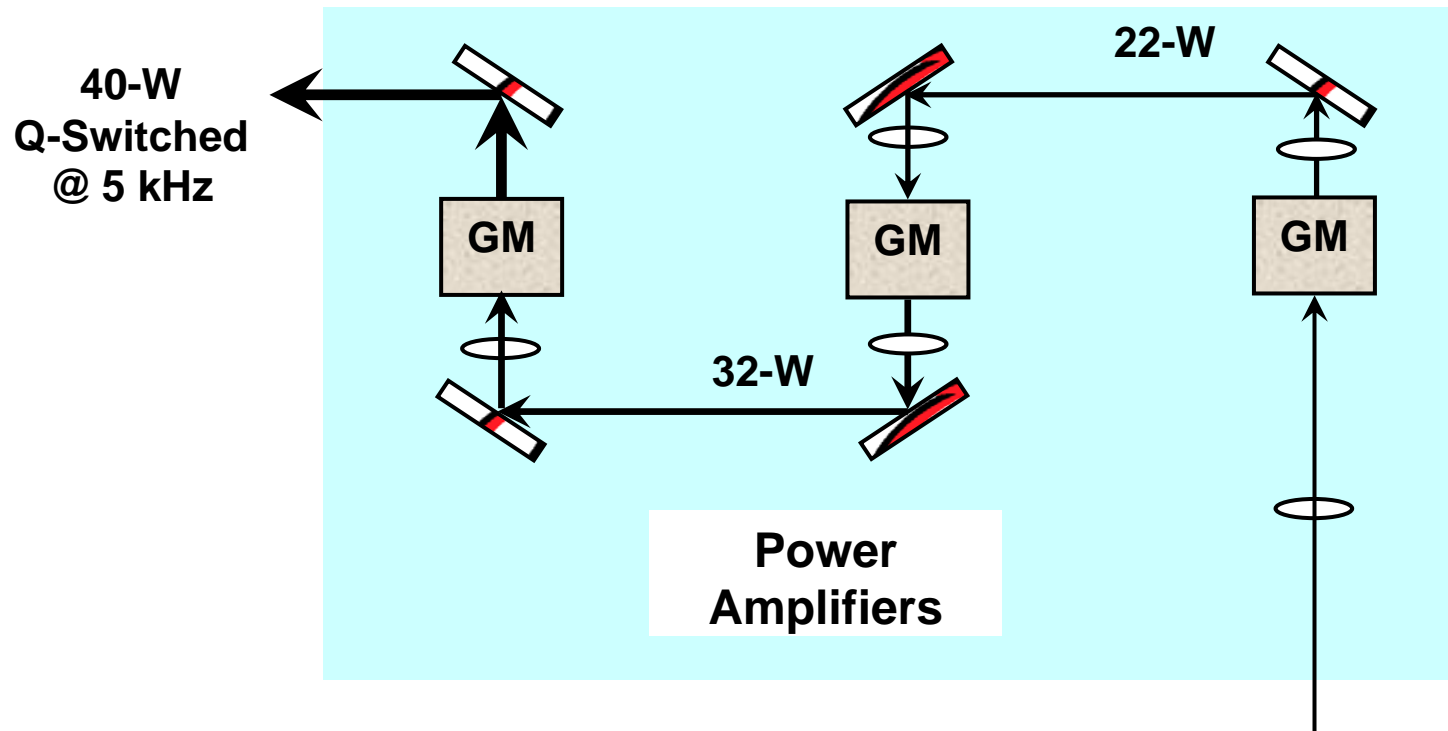

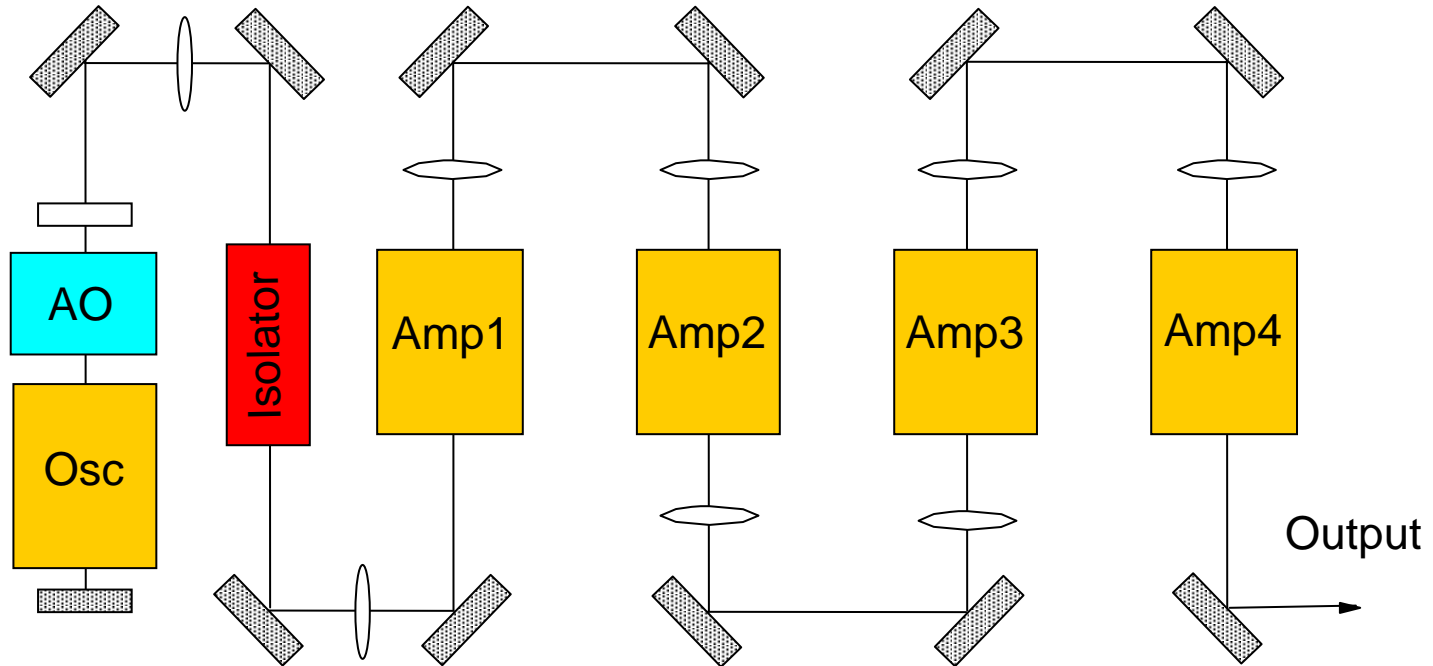

- **5 Gain Modules; 1 Oscillator, 4 Power Amplifiers. Same design for both 1064 nm and 1342 nm.**
- **Relay-imaged between master oscillator and amplifiers to preserve optimum beam size throughout the MOPA chain.**



Nd:YVO₄ MOPA Results

1064 nm

- **Outputs CW/Q-Switched @ 50 kHz**
 - Oscillator: 11.4 W / 10.5 W, 10 ns FWHM
 - Output: 53.5 W / 50.7 W, 10 ns FWHM, 1.01 mJ/pulse
101.4 kW Peak
- **200 W pump power → >25% optical, >10% electrical efficiency.**

1342 nm

- **Outputs CW/Q-switched @ 25 kHz**
 - Oscillator: 7.0 W / 6.3 W, 28 ns FWHM
 - Output: 24.5 W / 22.0 W, 28 ns FWHM, 0.88 mJ/pulse
31.4 kW Peak
- **200 W pump power → 12% optical, 5% electrical efficiency.**



Nd:YLF harmonic conversion generates visible, UV power (with Ushio)

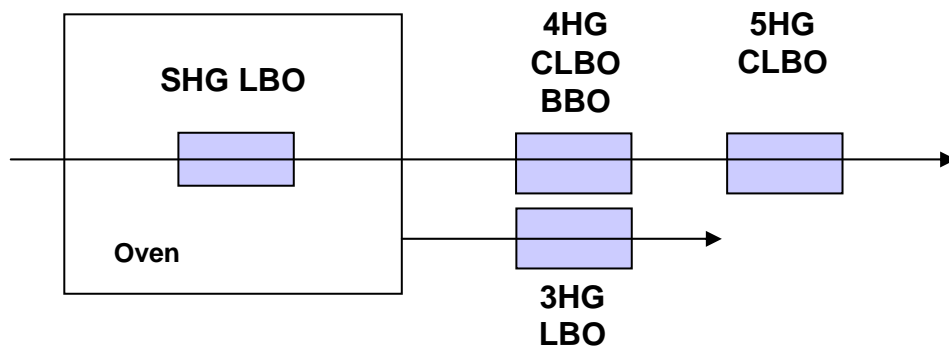

SHG (523.5 nm):
14 W at 5 kHz
and 68% conversion
in LBO

3HG (349 nm):
6 W at 10 kHz (30%)
15 W at 5 kHz

4HG (262 nm):
6.6 W (internal)
at 5 kHz with CLBO
2.5 W at 10 kHz in BBO

5HG (207 nm):
2 W (internal)
at 5 kHz with CLBO

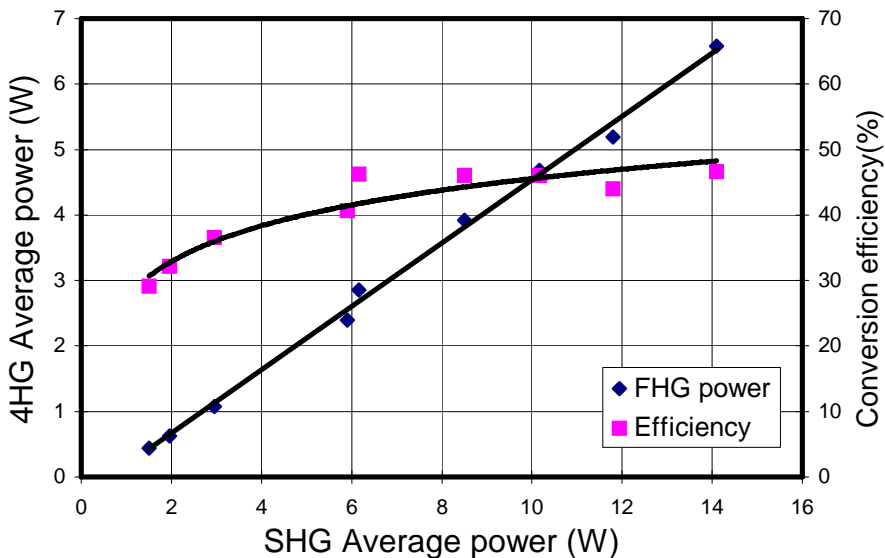

SHG theory with LBO doubler results

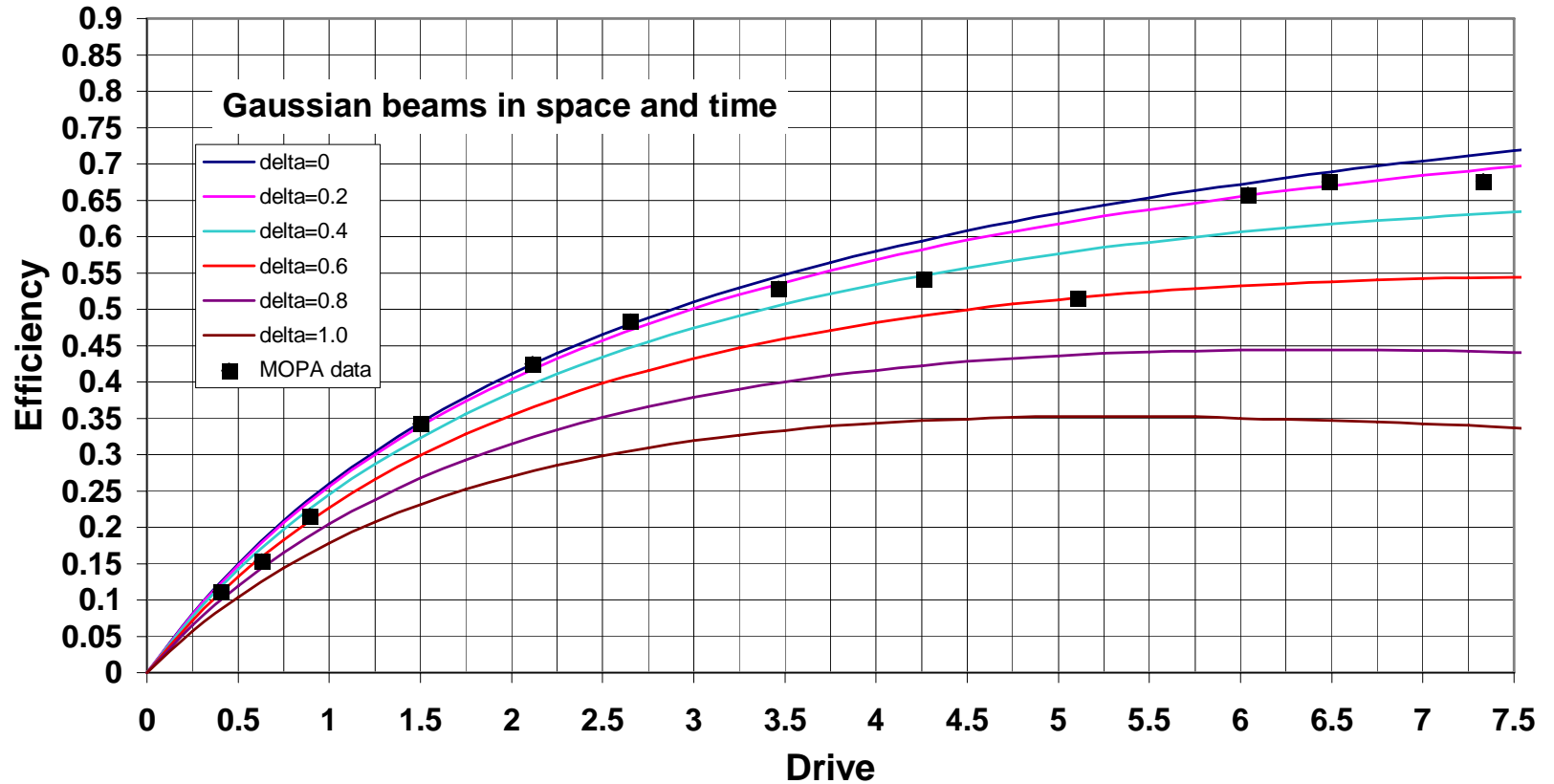



MPS-based 349-nm commercial product

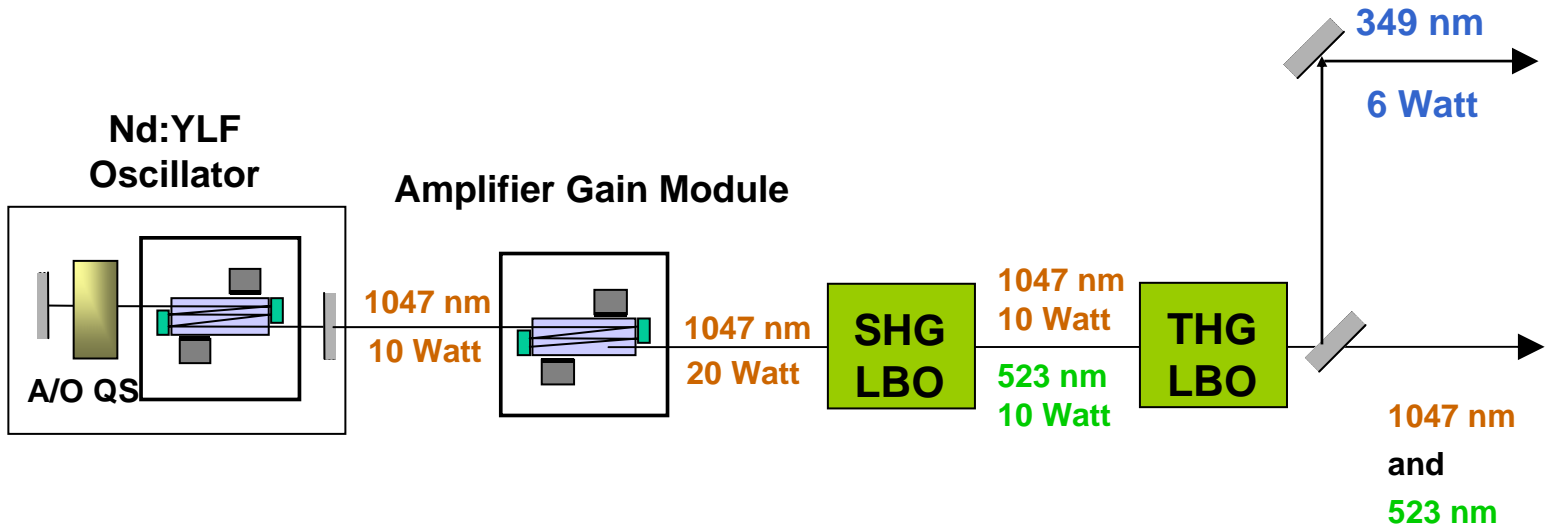



Average power vs. pulse rate, 349-nm laser

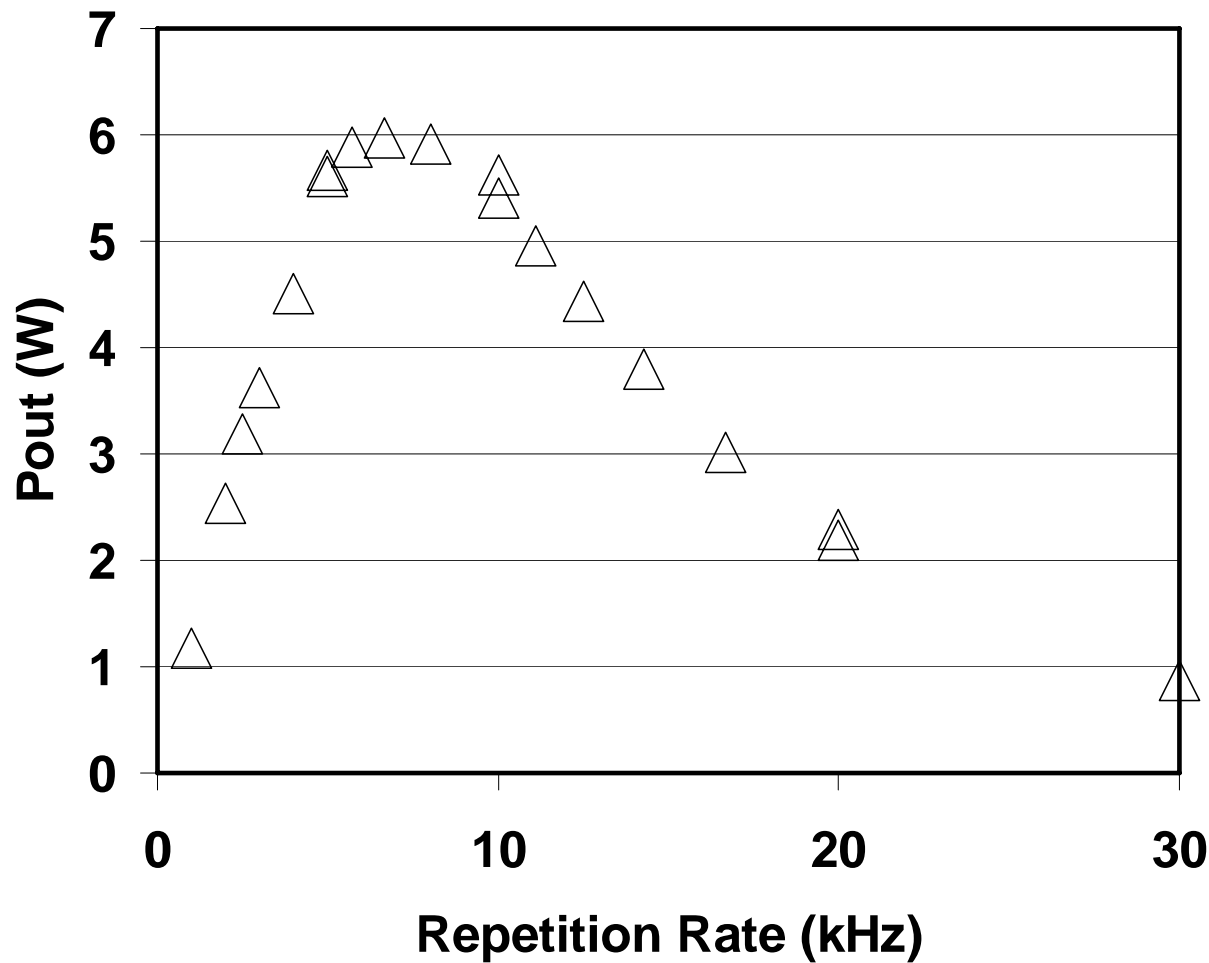



Development of solid state DUV sources

All-solid-state, 1-W, 5-kHz laser source below 200 nm

J. Sakuma, A. Finch, Y. Ohsako

USHIO Research Institute of Technology (Boston Research Laboratory),

135 South Road, Bedford MA 01730

Tel: 781 687 9127, Fax 781 687 9124,

E-mail : BYB03227@niftyserve.or.jp

K. Deki, M. Yoshino, M. Horiguchi, T. Yokota

USHIO Research Institute of Technology (Gotenba R&D Laboratory)

1-90 Komakado, Gotenba, Shizuoka 412-0038, Japan

Y. Mori, T. Sasaki

Department of Electrical Engineering, Osaka University

2-1 Yamadaoka, Suita, Osaka 565, Japan

MPS-based DUV source

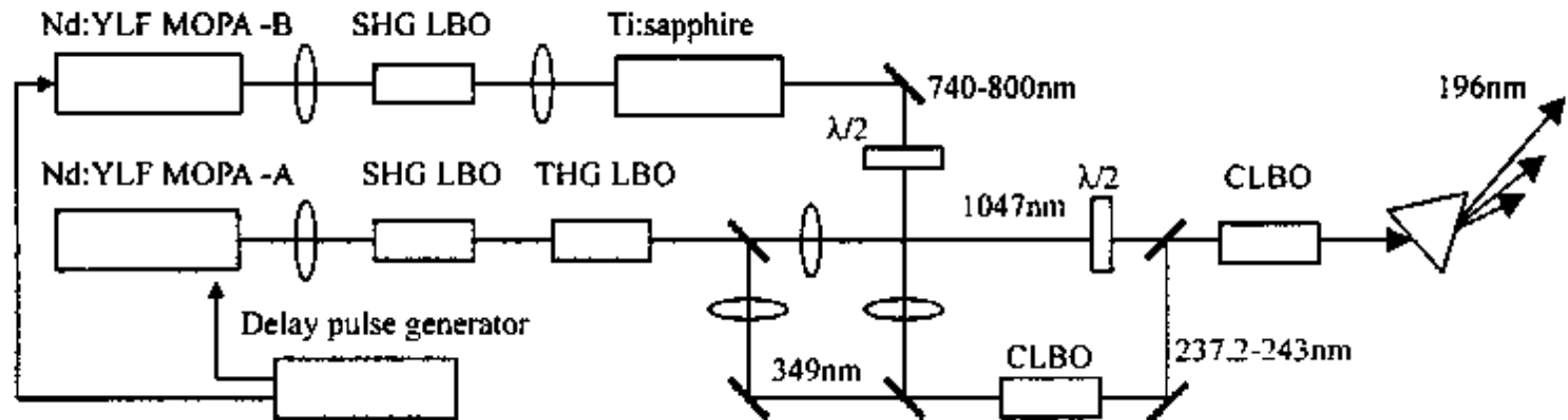

OPO-based RGB source driven by MPS

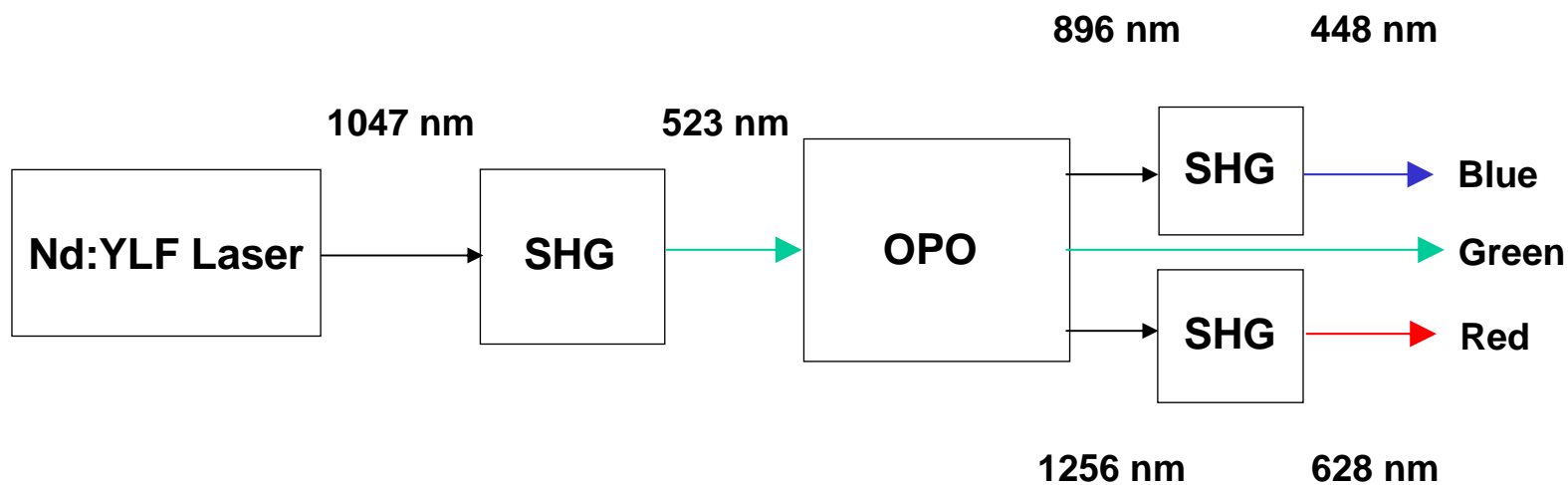

U.S. Patent #5,740,190



Intracavity OPO

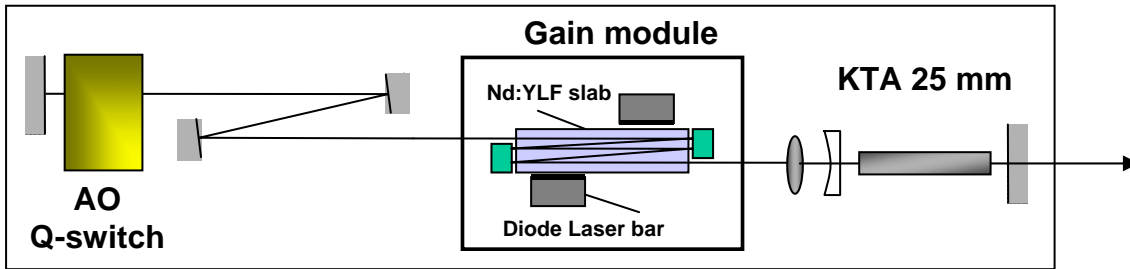

**1 W output
at 1507 nm
12.5 kHz PRR
6 ns pulsewidth**

External OPO

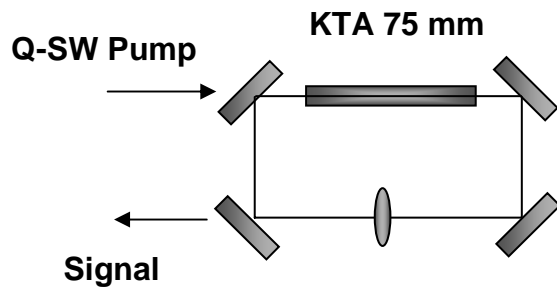

43% conversion to 1507 nm

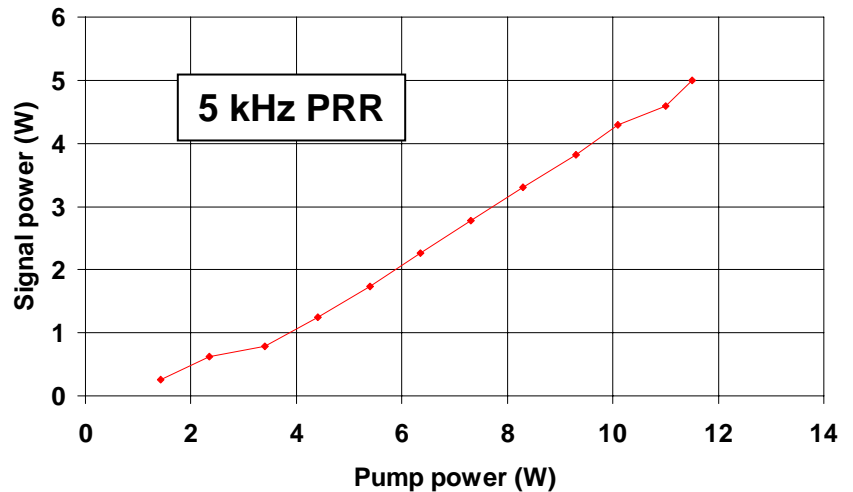



Data on IR OPOs pumped by MOPA system

- **Pump source: MOPA #2**
- **KTA OPO**
 - **60-mm crystal length, 80-degree cut**
 - 30 W pump, 5 kHz PRR
 - 10 W at 1530 nm, 3 W at 3340 nm
 - **40-mm crystal length, 60-degree cut**
 - 31 W pump, 5 kHz PRR
 - 2.5-5 W of idler tunable from 2100-3100 nm
- **PPLN OPO**
 - **19-mm crystal length, 30.8-um pitch**
 - 30 W pump, 5 kHz PRR
 - 5.2 W at 2610-nm idler, 3W at 1720-nm signal

Tuning curve for MPS-driven KTA OPO

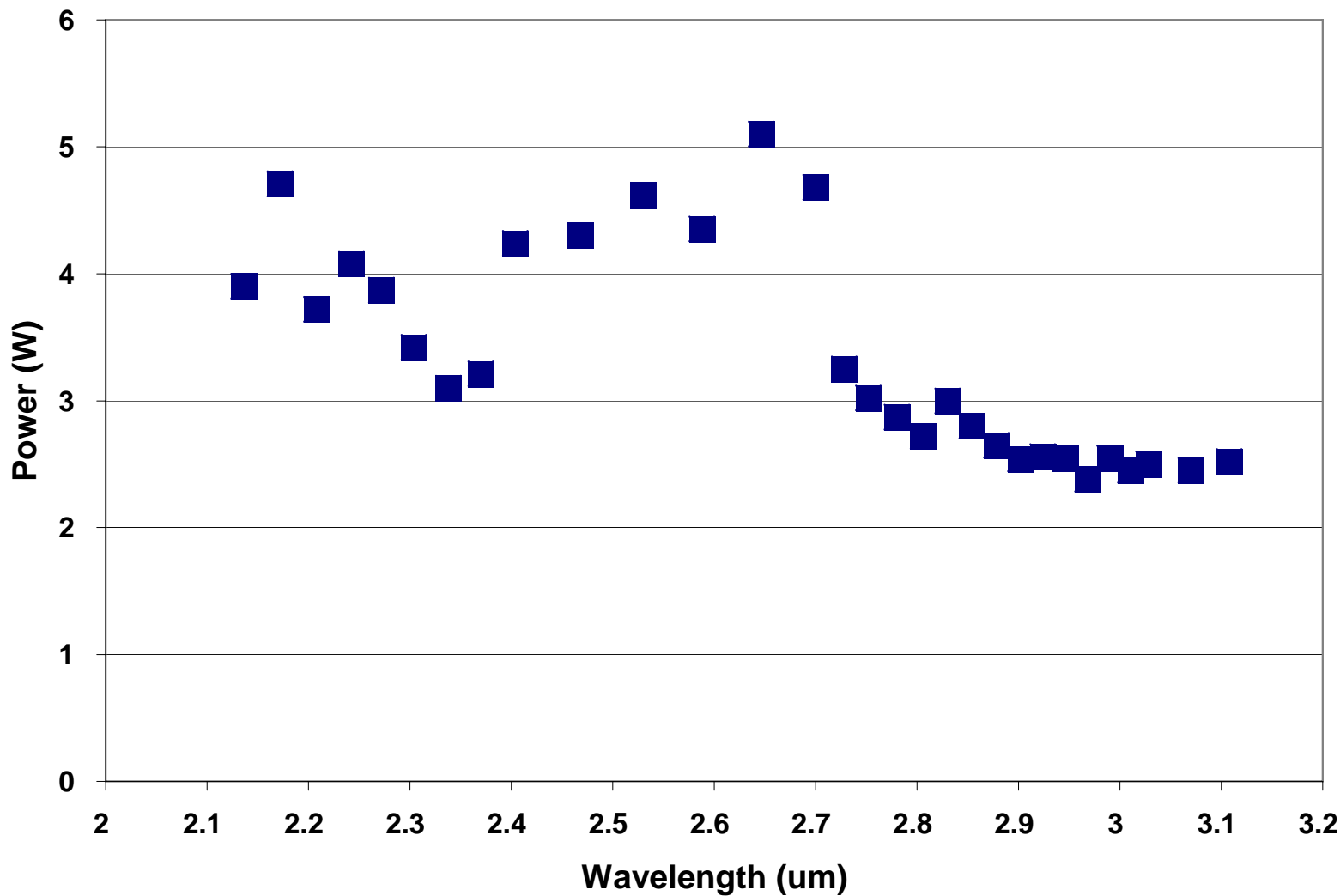

$\eta_{\text{slope}} > 50\%$ (no BRF in the Cavity)

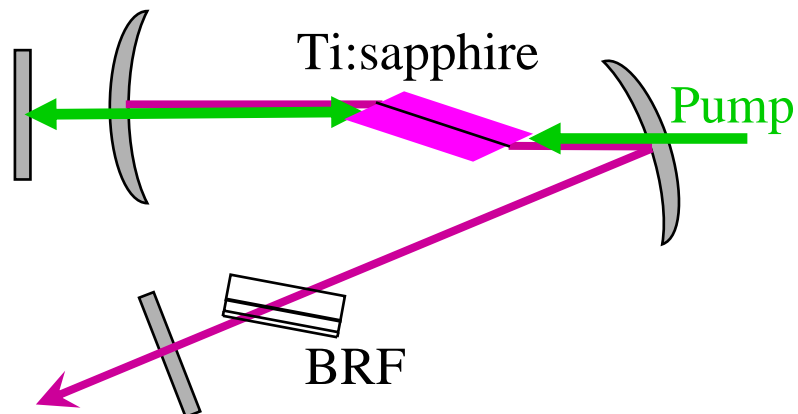
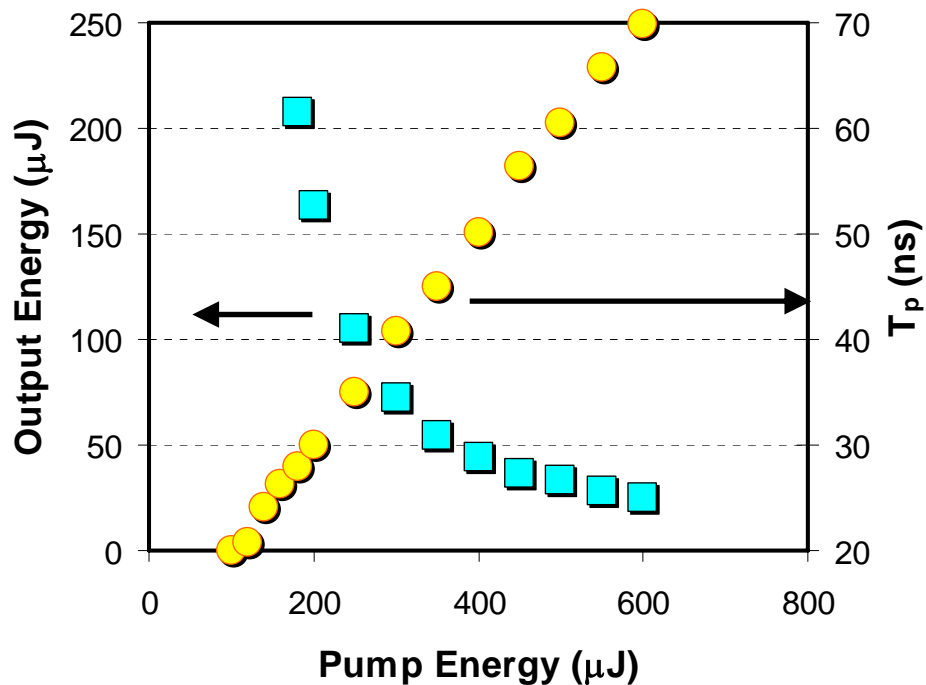

High-pulse-rate, tunable IR source

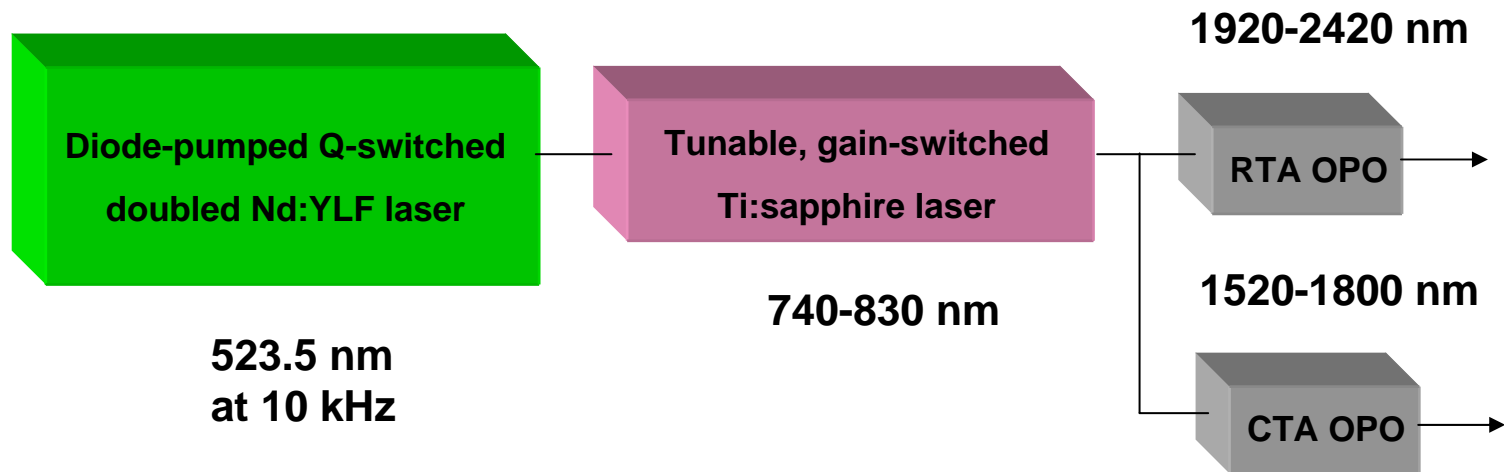

- **Side-pumped, multi-pass slab configurations can generate a unique combination of high powers and high beam quality from diode-pumped Nd:YLF and Nd:YVO₄ lasers**
 - Highest TEM₀₀ power from Nd:YLF (60 W CW)
 - Highest powers from a Nd:YVO₄ laser system:
 - 53.5 W CW, 50.7 W Q-switched at 1064 nm;
 - 24.5 W CW, 23.5 W Q-switched at 1342 nm.
- **The high gain of the multi-pass slab results in short pulses and high peak powers in Q-switched operation**
- **The lasers are ideal sources for high-repetition-rate, non-linear frequency generation**
 - Visible and UV sources via harmonic generation
 - RGB and tunable IR sources via parametric generation
- **Bring on some new nonlinear materials!**