

54
Highly Efficient, Transversely Pumped, 25-W, TEM₀₀
Nd:YLF Slab Laser

Dicky Lee, Kevin J. Snell, Kevin F. Wall and
Peter F. Moulton
Paper CTuE6, May 9
CLEO/QELS 2000
San Francisco, CA



- **Review of MPS design, performance**
- **Scaling results with higher-power pump lasers**
 - **CW performance**
 - **Q-switched performance**
- **MPS amplification of a SESAM mode-locked laser**
- **Conclusions**

Multi-pass slab (MPS) design is side-pumped

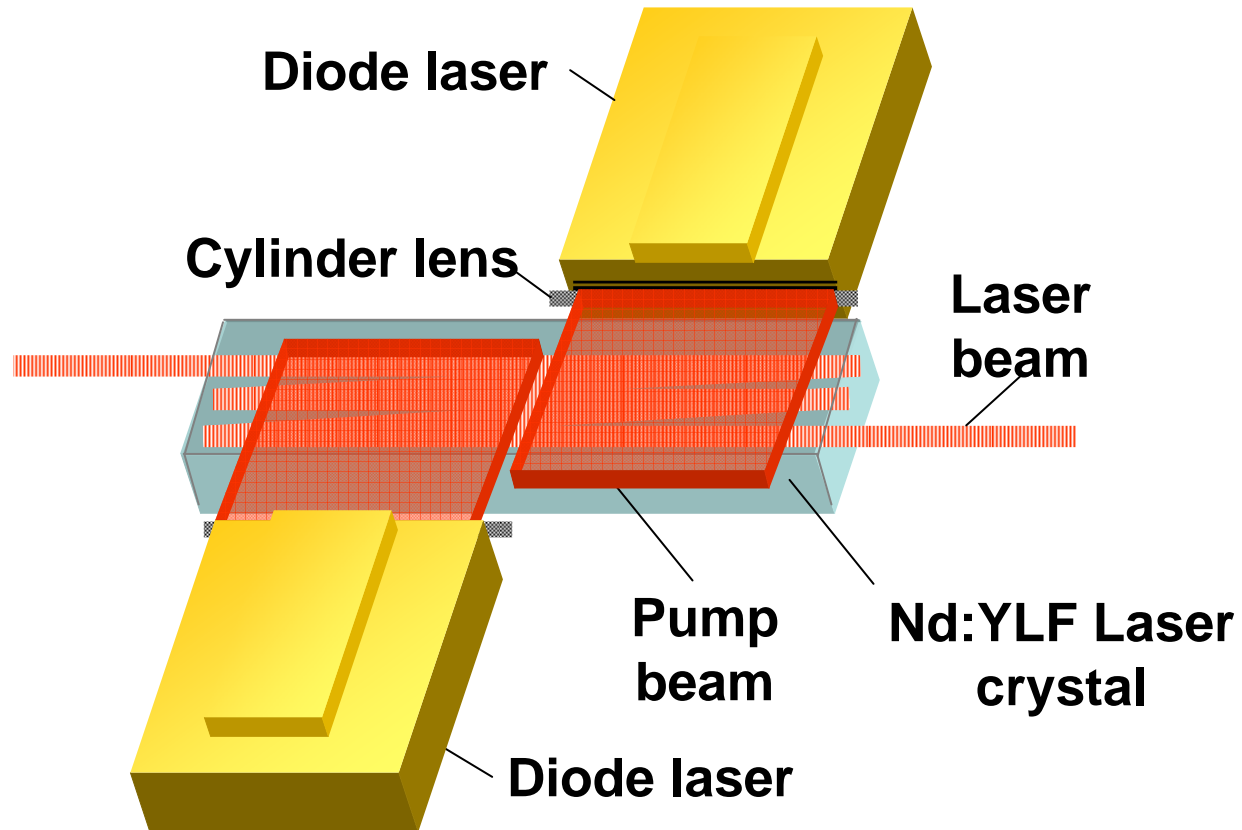

Resonator added makes a MPS oscillator

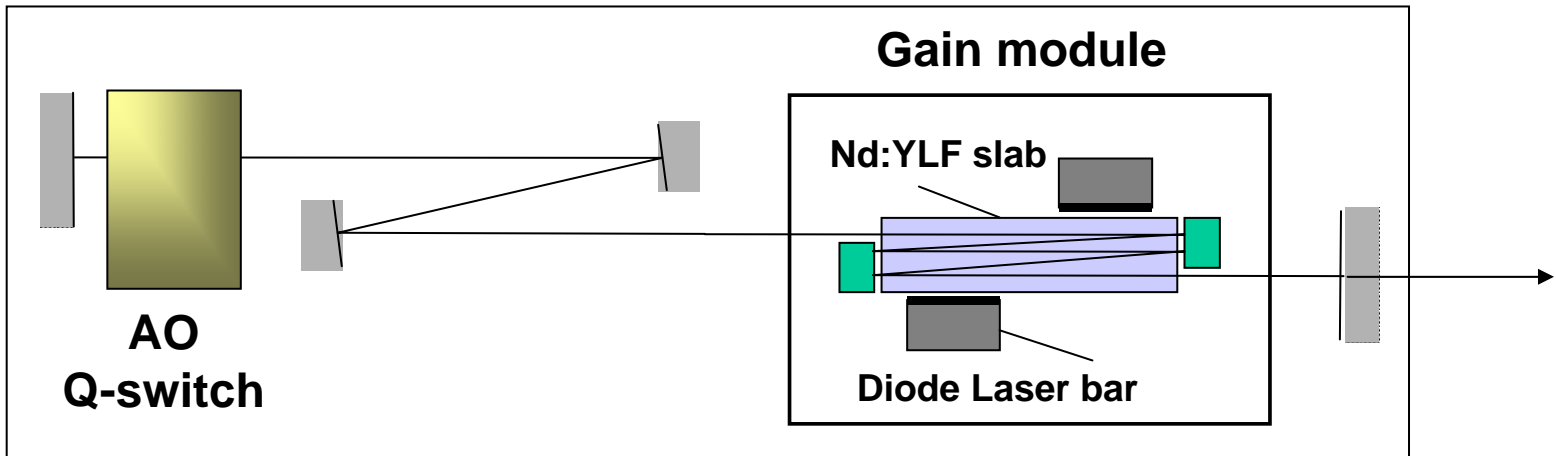

MOPA design allows scaling to 60 W cw

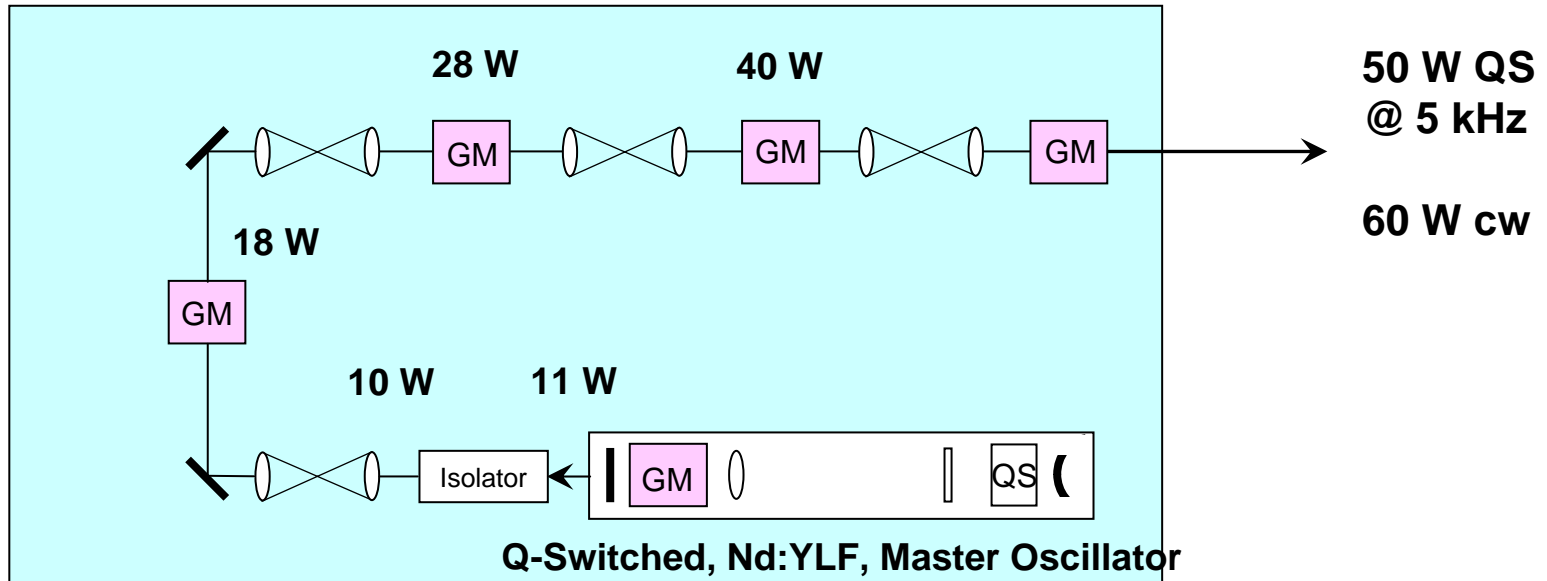

Relay Optics



Gain Module



Mirrors



AO Q Switch

Thermal Profile of Nd MPS

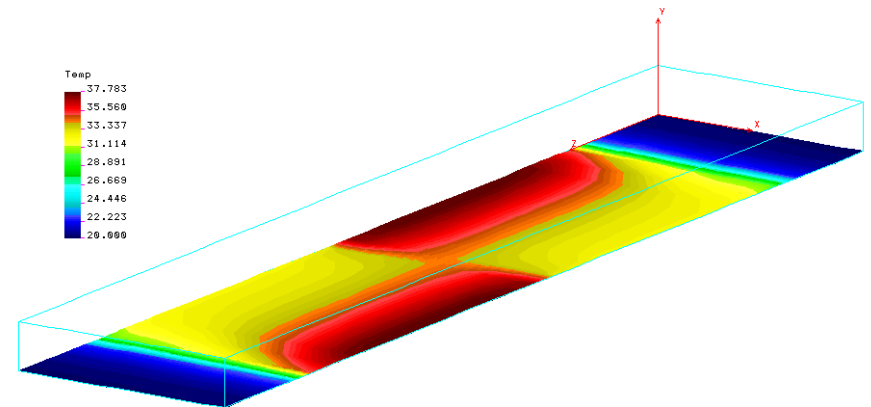
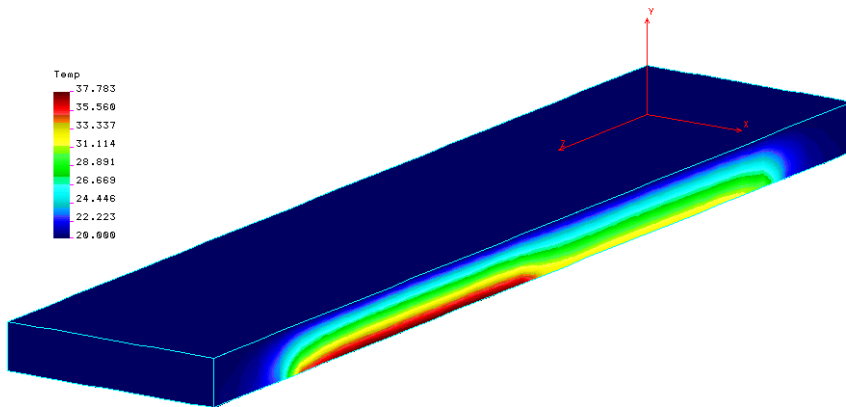

- Double-pass pumping
- Beer's law absorption
- $\alpha_{\text{eff}} = 2 \text{ cm}^{-1}$
- 20 W/diode



CW oscillator performance scales upward

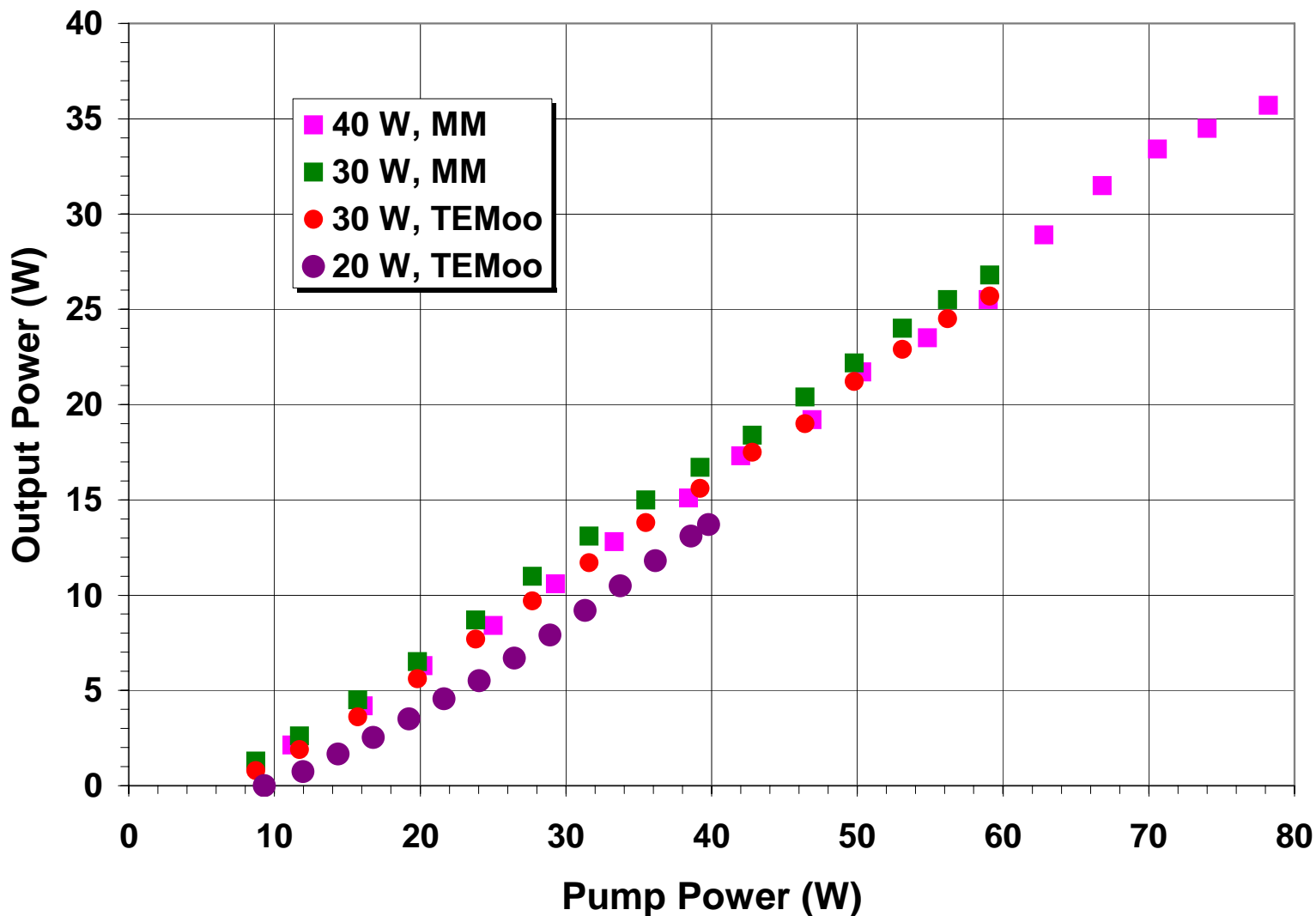

TEM₀₀ properties are power-independent

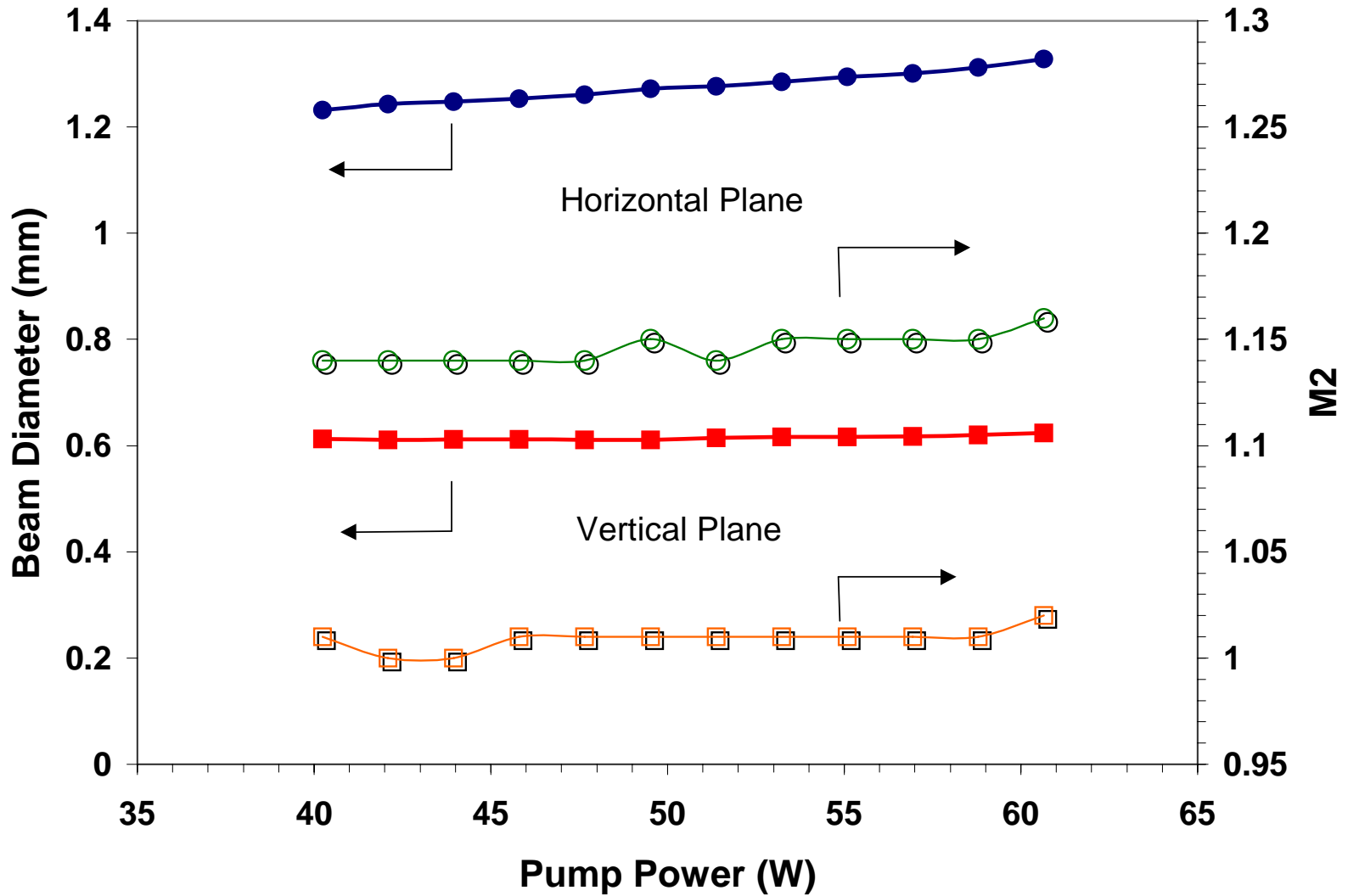



MOPA generates 54 W cw with one amplifier

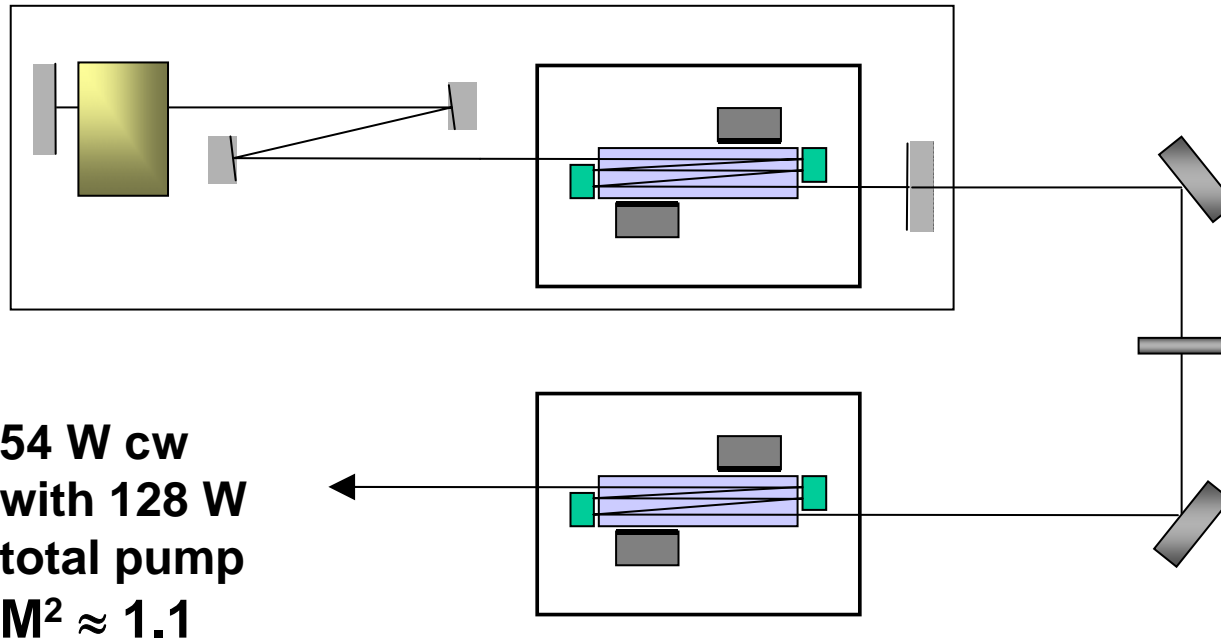



Q-switched average power is nearly doubled

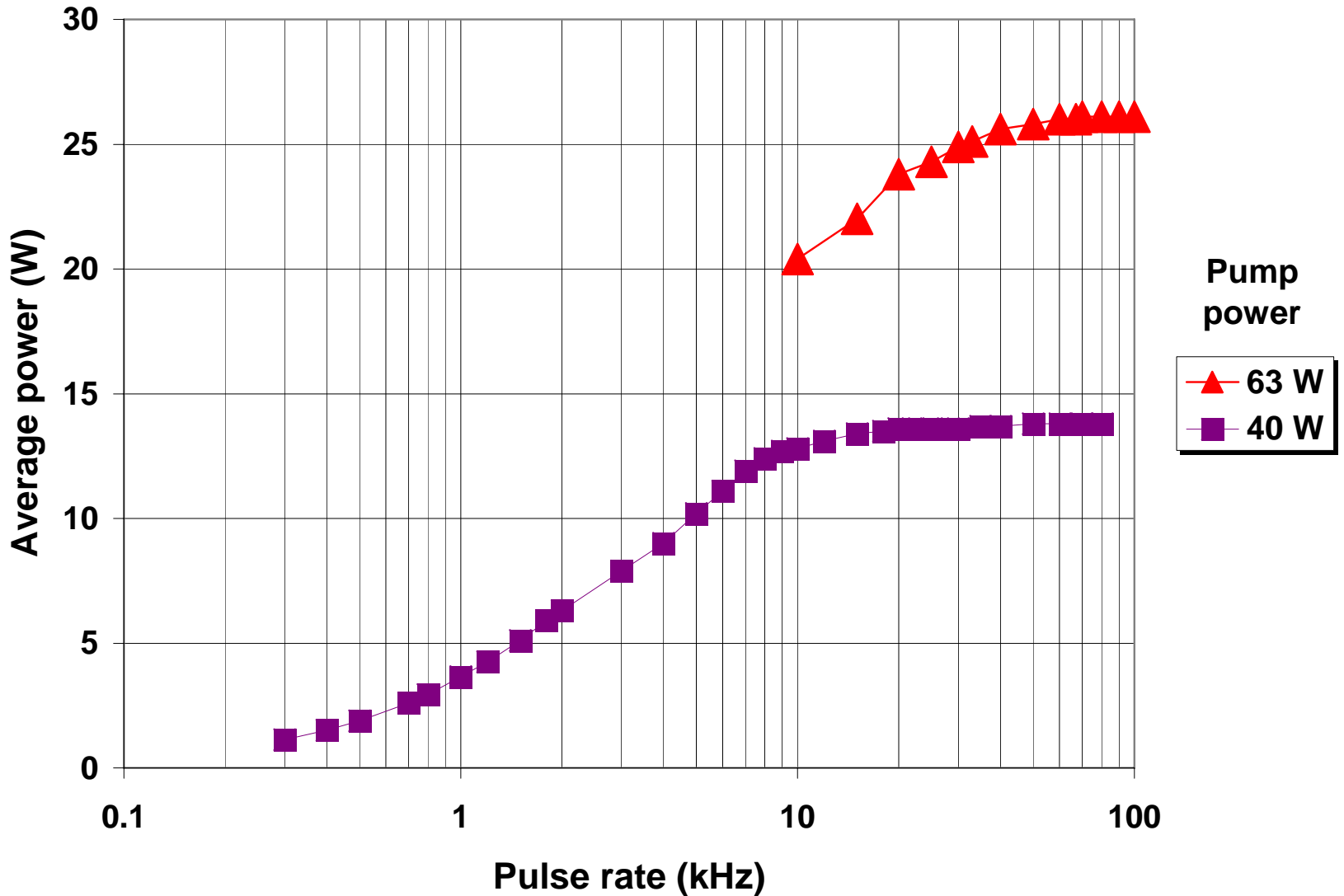

Higher gain yields shorter pulses

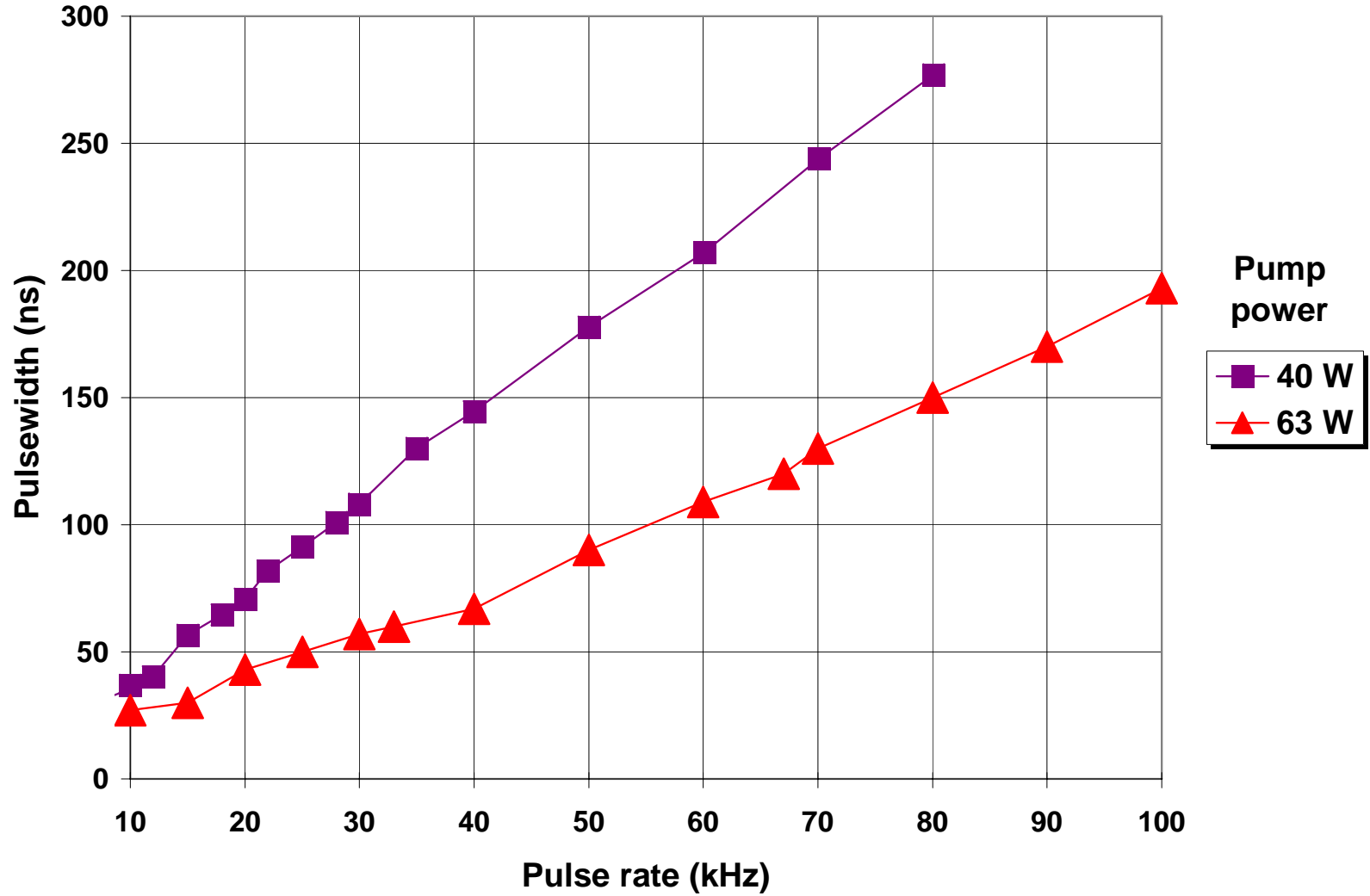



Peak power is increased at high PRR

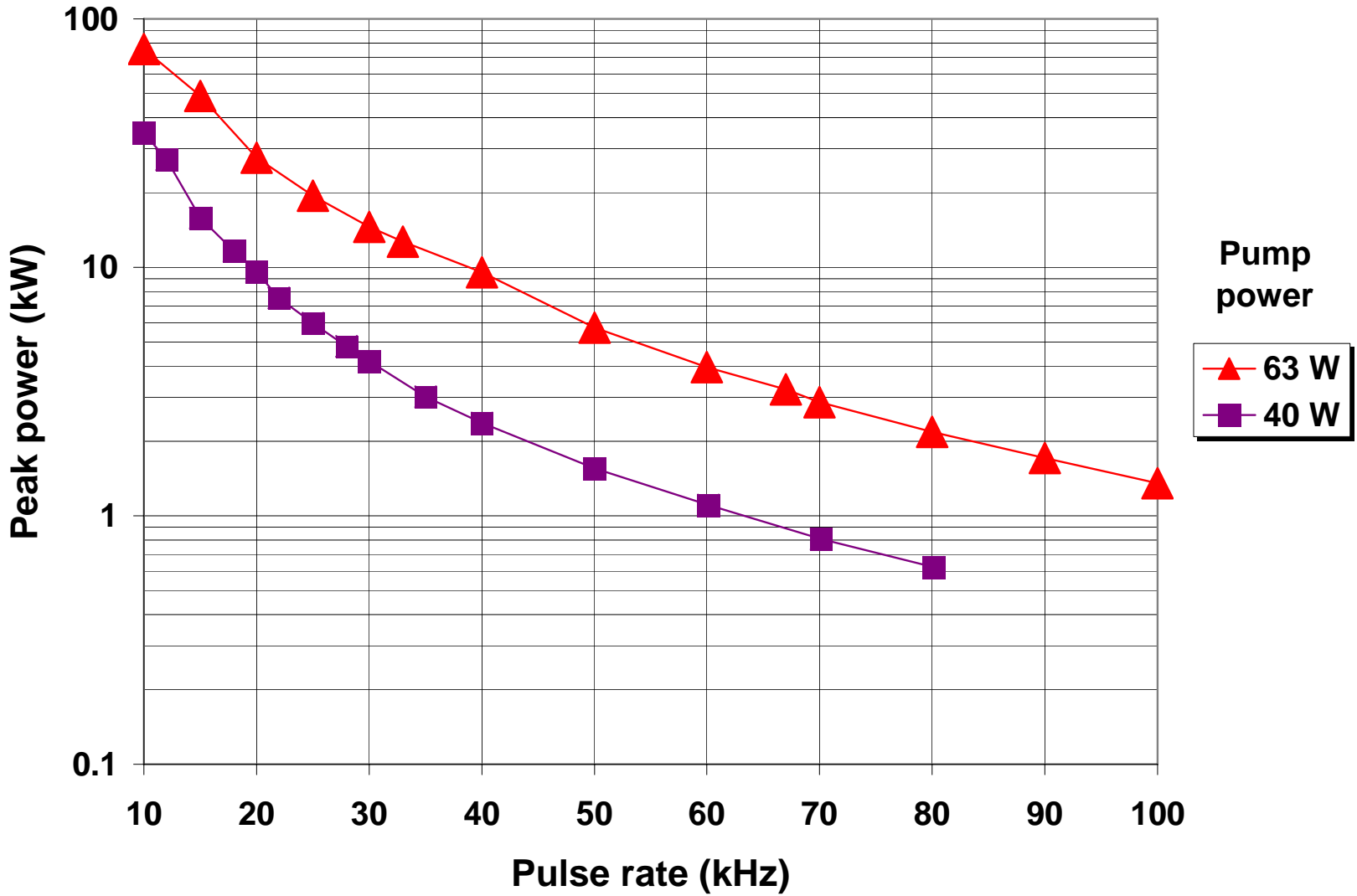

MPS modules amplify a mode-locked laser

0.7 W,
4.5 ps @100 MHz

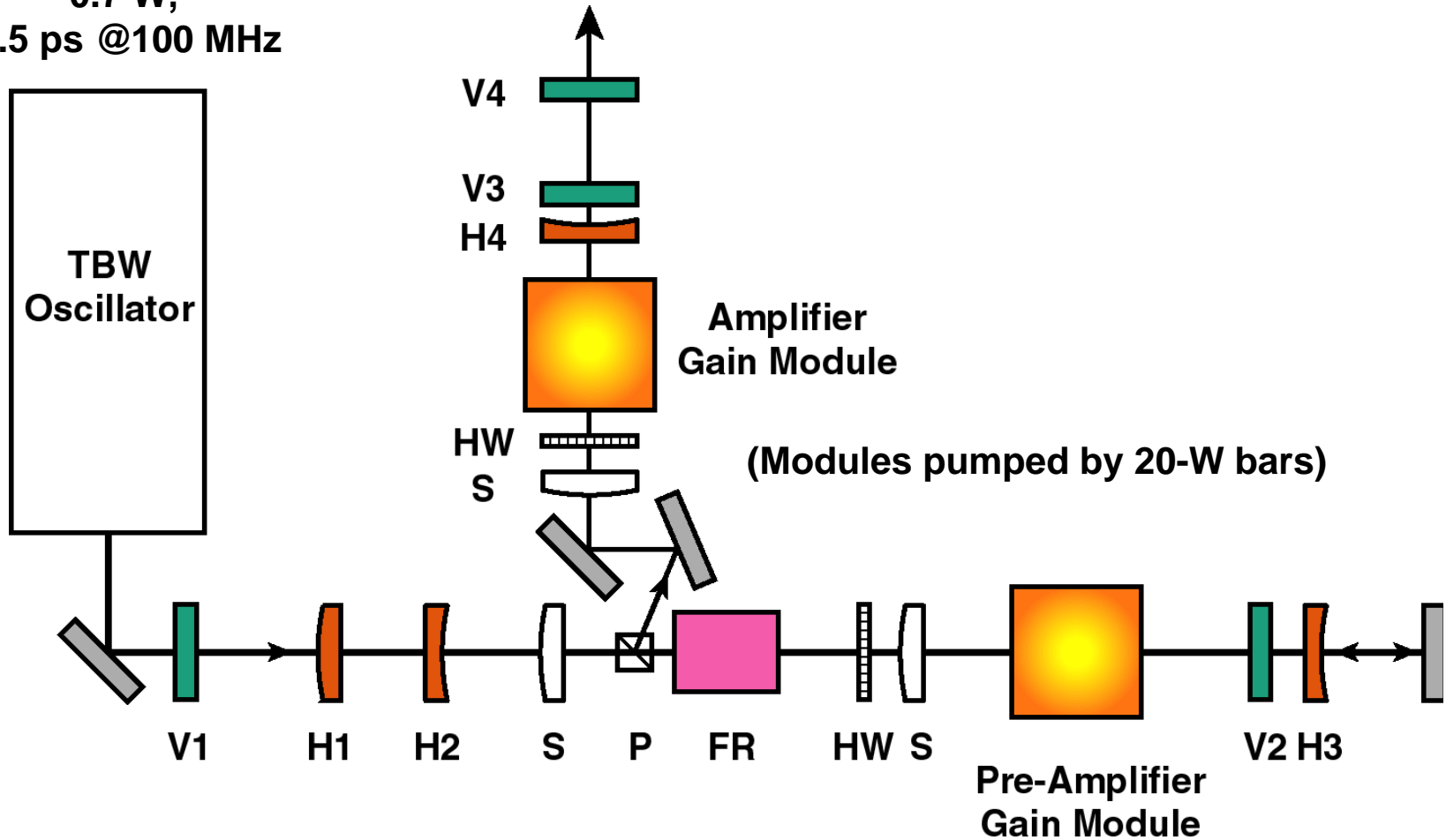

Preamp saturates at full pump power

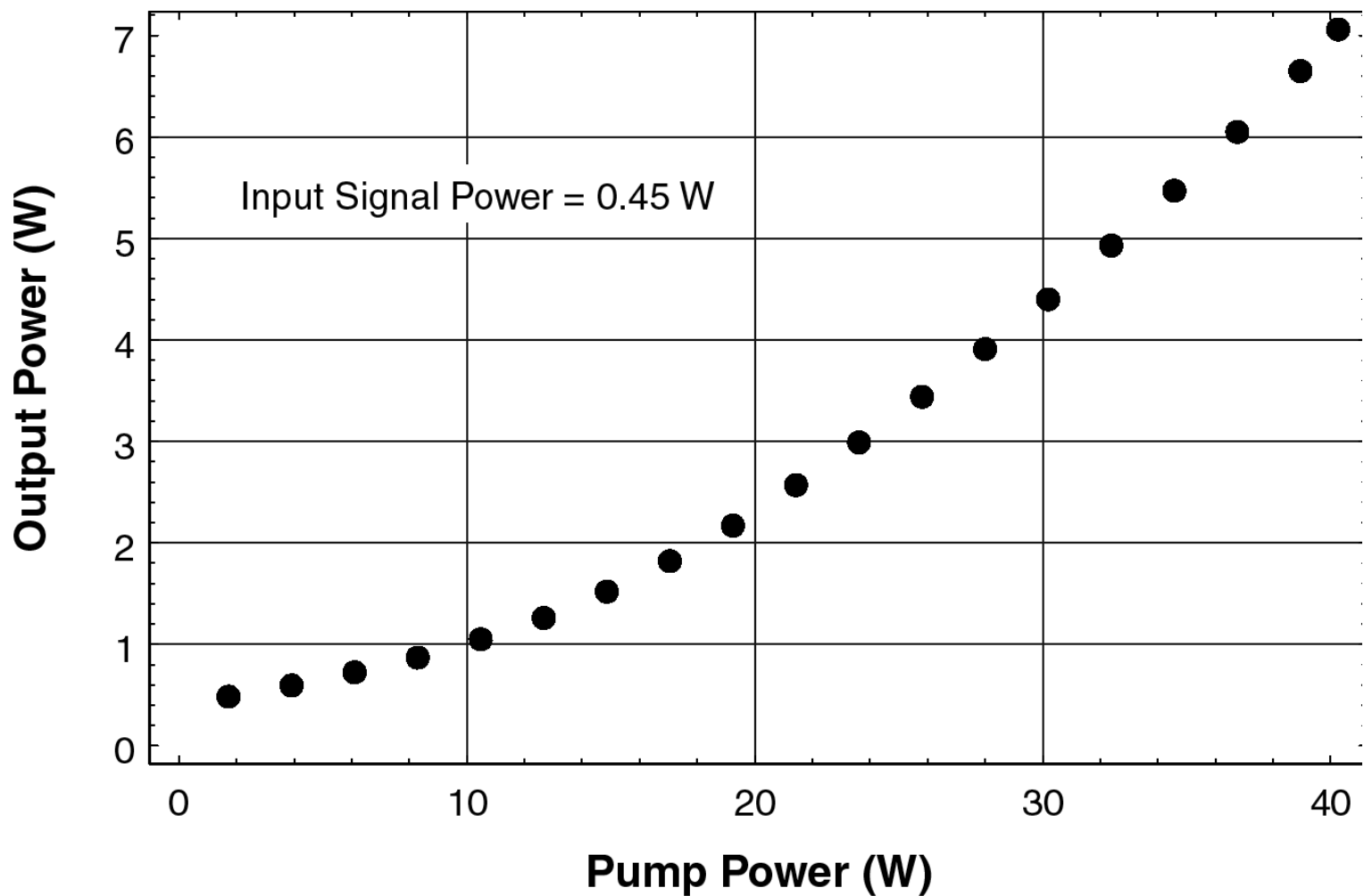

Amplified ML laser converts efficiently

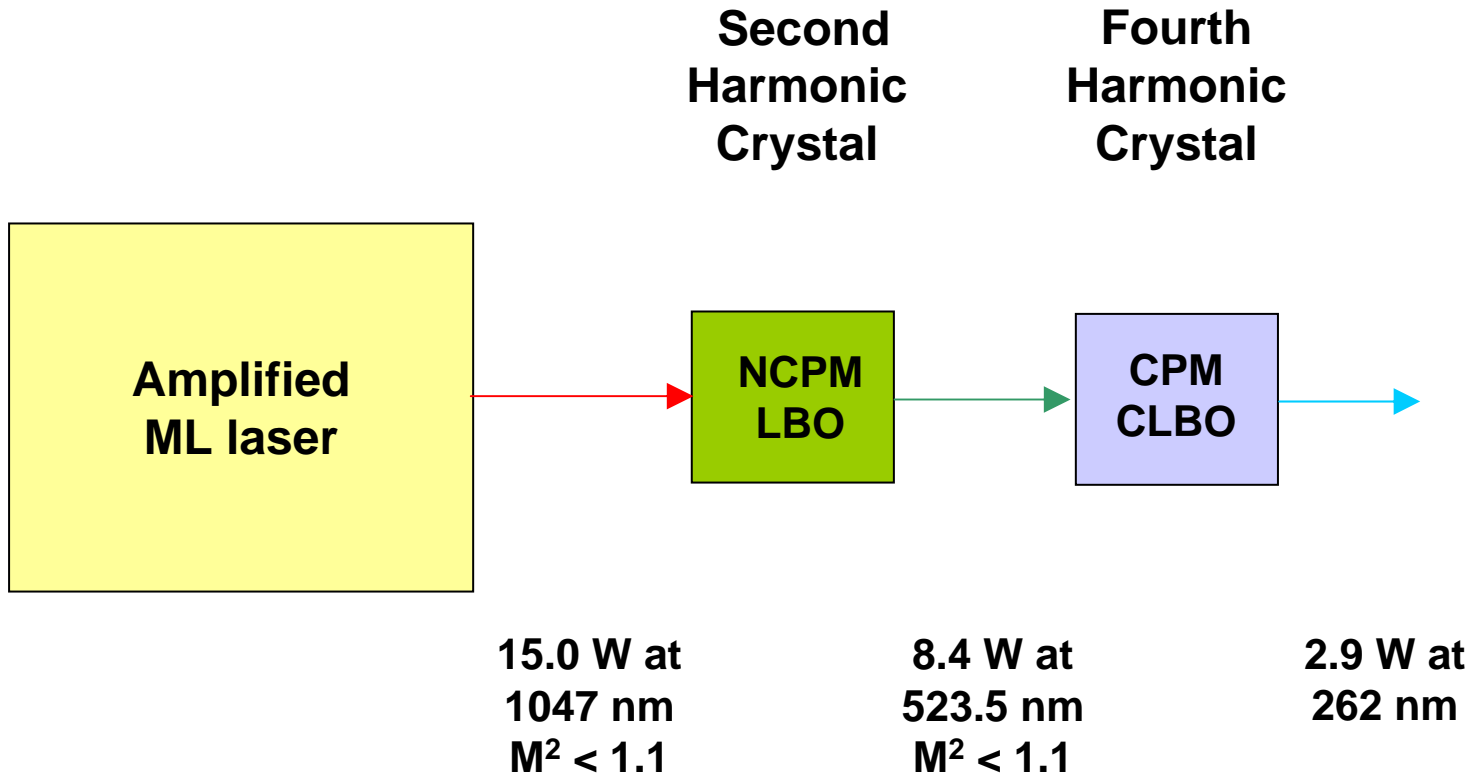

- **MPS design with Nd:YLF can be scaled in cw power with higher-power pump lasers**
 - 25.7 W TEM₀₀ oscillator with 59 W of pump
 - 36 W multimode with 79 W of pump
 - approaching 50% optical conversion, 20% electrical
 - MOPA with one amplifier generates 54 W TEM₀₀
- **MPS Q-switched performance enhanced in:**
 - average power (26 W for PRR >50 kHz)
 - peak powers for PRR > 10 kHz but
 - performance limited by holdoff, switching time of Q-switch
- **MPS amplifiers can increase power of SESAM mode-locked Nd:YLF laser**
 - 15.8 W average ($M^2 < 1.1$) for 4.5 ps pulses at 100 MHz
 - 8.8 W at second harmonic, 2.9 W at fourth
- **100 W average power next??**