

Pulsed, single-frequency, ring laser with a holographic output coupler

Alex Dergachev

Q-Peak, Inc., 135 South Road, Bedford, Massachusetts 01730

dergachev@qpeak.com

Abstract: A ring laser with reflective thick holographic grating as an output coupler is demonstrated. Unidirectional, passively Q-switched, 2.05- μm Ho:YLF ring laser provides single-frequency, 100-200-ns-long pulses at kHz rate.

OCIS codes: (140.3560) Lasers, ring; (140.3580) Lasers, solid-state

Coherent LIDAR applications require pulsed, narrow-linewidth laser sources operating in eye-safe wavelength regions near 1.5 and 2.0 μm . The application requirements for the spectral linewidth dictate that the minimum (time-bandwidth limited) laser pulsewidth has to be in 100-300-ns range. Typically such lasers are based on high-energy, injection-seeded, long-resonator, Q-switched oscillators, however, there is a significant potential in developing all amplifier architecture where a low power, Q-switched, single-frequency laser module is amplified directly to the required energy/power level.

This effort demonstrated a pulsed, single-frequency, ring Ho-oscillator which generates 100-200-ns pulses at kHz repetition rates with up to ~ 1 W of average power at ~ 2 - μm wavelength. The wavelength selection and “coarse” spectral narrowing is performed by utilizing a thick holographic grating (i.e. volume Bragg grating) [1,2] as a resonant, narrowband output coupler. Pulsed operation of the Ho-oscillator and further spectral narrowing is achieved via passive Q-switching using Cr^{2+} -doped saturable absorbers.

Ring resonators provide more flexibility in the laser oscillator design. Also unidirectional operation of a ring resonator allows to eliminate spatial hole-burning in the laser element which adversely affects the single-frequency operation. It is worth noting that in a passively Q-switched ring cavity the emitted photons are passing through the gain medium and the saturable absorber only once per roundtrip (as opposed to two passes in a standing wave cavity) resulting in generation of twice longer pulses than in a standing-wave cavity with the same roundtrip time and the same laser arrangement (laser crystal, saturable absorber, pump power and beam geometry) – a significant benefit in achieving the laser pulsewidth goal set for this development effort.

Cr^{2+} -doped II-VI materials (first developed as laser media at Livermore National Lab [3,4]) provide unique capability for mid-infrared laser development. The absorption spectral range of Cr^{2+} makes it suitable for passive Q-switching of Er, Tm, and Ho-doped lasers operating at 1.5-1.6 μm and 1.9-2.1 μm . Possibility of using Cr^{2+} -doped media as saturable absorbers was realized early and reported for passive Q-switching of 1.5- μm Er:glass laser [5] and 2- μm Ho:YAG and Tm:YAG lasers [6].

Our choice of 2- μm Ho-laser material (as opposed to 1.5- μm Er-lasers) is based on the fact that a much higher gain of Ho-medium allows efficient further amplification of the pulsed seed oscillator to provide the desired scaling of eye-safe laser output. This approach decreases the number of amplifying stages, simplifies the overall design and improves the electrical efficiency of the complete laser system as compared to 1.5- μm laser technology.

In principle 2- μm Ho-medium can have a tuning range of up to several 10's of nm. In order to set the desired lasing wavelength and narrow the spectral acceptance of the ring Ho-oscillator we attempted to utilize a holographic output coupler based on a reflective volume Bragg grating (VBG) instead of a dielectric partial reflector. However, as such thick holographic reflectors are designed to operate at normal incidence it is not obvious how to incorporate them in a ring resonator. To resolve this issue we developed a novel ring resonator scheme [7] as shown in Fig. 1. The key objective to incorporate a holographic reflector is achieved by utilizing a VBG element which is designed to operate not at normal incidence but at a small Bragg angle in the range 1-4 deg. Deviation of the design Bragg angle (BA) from normal incidence strongly affects the angular acceptance of a VBG element but has almost no effect on its spectral bandwidth [1,2]. As indicated in Ref. [2] the reflective VBG has its largest angular acceptance bandwidth as long as the design Bragg angle is not exceeding the “threshold” value defined as: $\tan^2 \theta_0 = 2\delta\lambda^{\text{HWFZ}}/3\lambda_0$, where $\delta\lambda^{\text{HWFZ}}$ is the wavelength difference between the central peak and the first zero in the dependence of diffraction efficiency vs wavelength detuning from the design wavelength λ_0 . Assuming the desired $\delta\lambda^{\text{HWFZ}} \sim 0.23$ nm at $\lambda \sim 2.05$ μm we calculate the “threshold” angle as ~ 0.5 deg. If the design Bragg angle is increased beyond the threshold value the angular acceptance bandwidth is rapidly decreasing. For example,

assuming a VBG with ~90% reflectivity at 2.05 μm the calculated angular bandwidth for Bragg reflection peak (FWHM) is ~9 mrad for BA =1 deg, ~4.3 mrad at BA=2 deg, and ~2.2 mrad at BA =4 deg.

Larger angular bandwidth for the Bragg reflector is advantageous as it allows to design less misalignment sensitive ring resonators, improves wavelength stability and simplifies the laser assembly. On the other hand the VBG output coupler should be designed to operate at an angle of incidence large enough to provide sufficient angular separation between the incident and reflected beams so that ring resonator can be constructed. The ultimate upper limit on the design Bragg angle for a VBG element is determined by the divergence of the lasing mode in a particular resonator: the beam divergence should not exceed the angular acceptance bandwidth of a VBG reflector.

The VBG reflector for this effort was designed to provide ~90% reflectivity near 2.05 μm at ~1 deg Bragg angle with spectral selectivity of 0.25-0.3 nm (FWHM) and fabricated at Optigrate, Inc. The VBG resonance wavelength near 2.05 μm corresponds to the strongest emission peak in Ho:YLF. Also the narrow spectral bandwidth of VBG element prevents the lasing at 2.06 μm (which occurs first in Ho:YLF lasers at low inversion levels and low output coupling) regardless of the pump power.

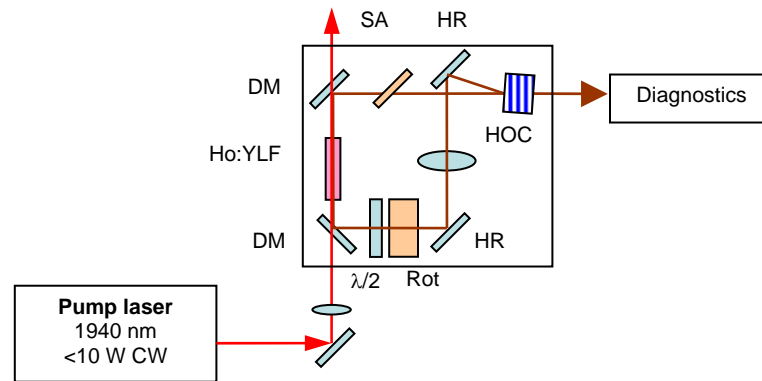

Fig. 1. Schematic drawings of the ring Ho:YLF oscillator (SA - saturable absorber, HOC –holographic output coupler, DM – dichroic mirror, Rot - Faraday rotator).

The Ho:YLF ring oscillator set-up (see Fig. 1) was based on longitudinal pumping scheme. A single spherical lens was used to assure stability of the ring cavity. Based on ABCD-matrix formalism the diameter of fundamental mode in the laser crystal for ~30-cm-long ring resonator was calculated to be ~700 μm . Single 0.5% Ho:YLF crystal was pumped from one side by a Tm-fiber laser (IPG Photonics) wavelength-adjusted to the strongest Ho:YLF absorption line at 1940 nm. Tm-fiber laser produced collimated, linearly-polarized, diffraction-limited beam with less than 2-nm linewidth and maximum average power of ~10 W. Unidirectional operation of the ring resonator was achieved with an intra-cavity optical “diode” based on a Faraday rotator and a waveplate. Ho:YLF crystal mount was temperature controlled using a TE-element. The ratio of pump to laser wavelengths is ~0.95, indicating that about 5% of the pump power is dissipated as heat. The very modest amount of heat in the Ho:YLF crystal leads to minimal thermal distortion and stresses - all benefits for stable operation in single-frequency regime.

Cr^{2+} :ZnSe saturable absorber with initial transmission of $T_0 \sim 95\%$ at ~2.05 μm was utilized in the experiments. Passive Q-switch element was fabricated by Photonics Innovations, Inc. (now part of IPG Photonics).

Ho:YLF ring oscillator operated in TEM_{00} mode and produced average power output of up to 1.9 W in CW and 1.4 W Q-switched regimes at maximum pump power of ~9 W. The ratio of average power in Q-switched regime to that in CW regime is ~0.74. For VBG reflectivity of ~90% and initial transmission of saturable absorber of ~95% we measured the maximum repetition rate range of 3.3 kHz and maximum attainable pulse energy of 0.42 mJ while maintaining single-frequency laser operation. We estimate the spectral linewidth to be transform limited (what is typical for passively Q-switched oscillators). The lasing wavelength of the ring oscillator was measured to be 2050.39 nm.

Dependence of the output pulse energy and pulse repetition rate for the ring Ho:YLF oscillator with VBG output coupler is shown in Fig. 2. The laser pulse energy exhibited non-linear dependence on the pump power increasing by ~1.6 times from 0.26 to 0.42 mJ as the pump power increased from ~4.5 W to 9 W (see Fig. 2). The dependence of the repetition rate vs pump 1.9- μm power can be closely approximated by a linear fit with ~600 Hz/W slope.

The laser pulsewidth exhibited slight dependence on the pump power showing decrease from ~175 ns to ~140 ns as the pump power increased from ~4.5 W to 9 W. This pump power change corresponded to the increase of the repetition rate from ~0.6 kHz to ~3.3 kHz (or the decrease of the pulse period from ~1600 μs to ~300 μs).

For temporal/FFT pulse measurements we utilized a fast PIN InGaAs detector which has a usable spectral range of 830~2100 nm, cutoff frequency of ~10 GHz and rise/fall time of <35 ps and an oscilloscope with ~6 GHz bandwidth. The photodetector/oscilloscope combination allowed us to resolve mode beating at up to ~6 GHz level, which was more than sufficient for characterization of our ring oscillator layouts with typical mode spacing of <1 GHz. The oscillator spectral properties were also studied with a Fabry-Perot interferometer.

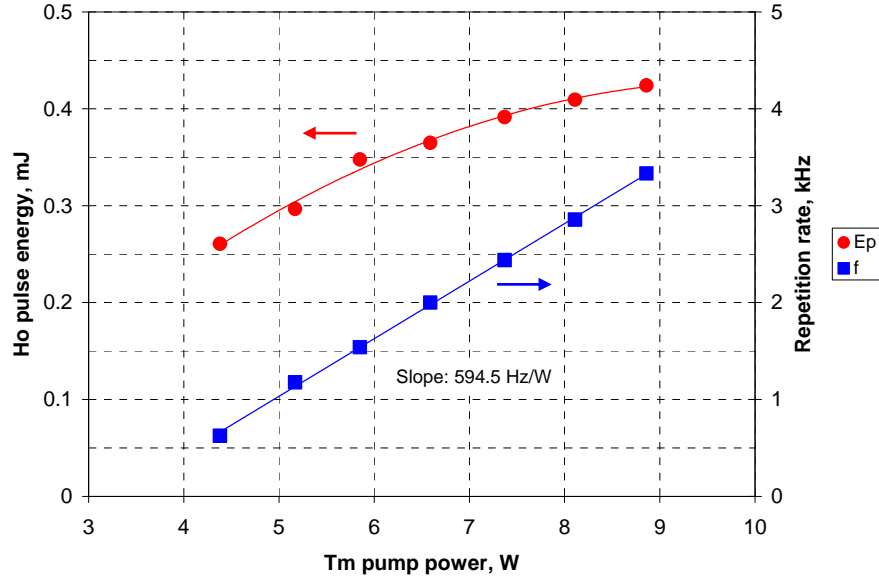

Fig. 2. Pulse energy (circles) and repetition rate (squares) vs pump power for a ring Ho:YLF oscillator with VBG output coupler and ~95%-transmissive Cr^{2+} :ZnSe saturable absorber.

In conclusion, laser operation of a 2.05- μm , single-frequency, passively Q-switched, bulk Ho:YLF oscillator based on a novel unidirectional ring resonator under 1.9- μm pumping was demonstrated and characterized. Long (140-175 ns), near transform-limited single-frequency laser pulses with pulse energy of ~0.4 mJ at up to 3.3 kHz repetition rate were generated in a bulk Ho:YLF ring oscillator. Such a pulsed, low-average-power laser can be used as a master oscillator in several remote-sensing applications, particularly in coherent LIDAR transmitters. Addition of bulk high-gain Ho-amplifier stage allows easy scaling to multi-mJ pulse energies. Given the nature of the bulk crystal amplifiers, they provide damage-free operation and are immune to nonlinear effects such as Brillouin and Raman scattering which adversely affect the amplification of single-frequency seed sources in fiber amplifiers.

This work was supported by NASA grant NNX10CE95P.

References

- [1] H. Kogelnik, "Coupled wave theory for thick hologram gratings," *Bell Syst. Tech. J.* **48**, 2909–2945 (1969)
- [2] I.V. Ciapurin, L.B. Glebov, V.I. Smirnov, "Modeling of Gaussian beam diffraction on volume Bragg gratings in PTR glass", in *Practical Holography XIX: Materials and Applications*, T.H. Jeong, H.I. Bjelkhagen, eds., Vol. 5742, Proc. SPIE (SPIE, Bellingham, WA, 2005), p. 183-194.
- [3] L.D. DeLoach, R.H. Page, G.D. Wilke, S.A. Payne, and W.F. Krupke, "Transition metal-doped zinc chalcogenides: spectroscopy and laser demonstration of a new class of gain media", *IEEE J. Quant. El.* **32**, 885-895 (1996).
- [4] R.H. Page, K.I. Schaffers, L.D. DeLoach, G.D. Wilke, F.D. Patel, J.B. Tassano, Jr., S.A. Payne, W.F. Krupke, K.T. Chen, and A. Burger, "Cr²⁺-doped zinc chalcogenides as efficient, widely tunable mid-infrared lasers", *IEEE J. Quant. El.* **33**, 609-619 (1997).
- [5] A.V. Podlipensky, V.G. Shcherbitsky, N.V. Kuleshov, V.P. Mikhailov, V.I. Levchenko, and V.N. Yakimovich, "Cr²⁺:ZnSe and Co²⁺:ZnSe saturable-absorber Q switches for 1.54- μm Er:glass lasers," *Opt. Lett.* **24**, 960-962 (1999)
- [6] T.Y. Tsai and M. Birnbaum, "Q-Switched 2- μm lasers by use of a Cr²⁺:ZnSe saturable absorber," *Appl. Opt.* **40**, 6633-6637 (2001)
- [7] A. Dergachev, "Ring resonator with holographic reflector", Patent pending.