

A 40-W, Single-Frequency, Nd:YLF Master-Oscillator/Power-Amplifier System

**Kevin F. Wall, Martin Jaskan, Alex Dergachev,
Archana Szpak, John H. Flint, and Peter F. Moulton**

**Advanced Solid-State Lasers Topical Meeting
Boston, Massachusetts
February 1, 1999**



- **Very brief introduction**
- **Nd:YLF MPS gain modules**
- **Seed laser**
- **Single-frequency ring laser**
- **Amplifier chain**

- **Researchers**
 - Jim Harrison and Andy Finch
 - Rob Martinsen (Lightwave Atmospheric Inc.)
 - Jeff Manni (JGM Associates)
- **Technical Support**
 - Fab Brennan
 - Al Tid
 - Mike Michalik (Lumen Labs)
 -
- **Support**
 - Ushio, Inc.

- **Advantages**

- **Weak thermal lensing reduces the coupling between beam properties and average power \Rightarrow power scaling!**
- **Natural birefringence eliminates depolarization due to stress-induced birefringence**
- **Long upper state lifetime ($\sim 525 \mu\text{s}$) maximizes Q-switch pulse energy**

- **Challenges**

- **Thermal fracture is a greater concern than with Nd:YAG (However, we seldom fracture Nd:YLF.)**

- **Longitudinal Pumping (“End Pumping”)**

High degree of overlap between the laser mode and pump volume; requires high brightness diode lasers

⇒ High efficiency

⇒ High thermal density ⇒ Large thermally induced lensing, birefringence, and thermal fracture

- **Transverse Pumping (“Side Pumping”)**

Challenging to get good overlap between laser mode and pump volume; can use lower brightness diode lasers

⇒ Lower efficiency than longitudinal pumping

⇒ Lower thermal density ⇒ Lower thermally induced lensing, birefringence, and thermal fracture

Nd:YLF MPS Gain Module

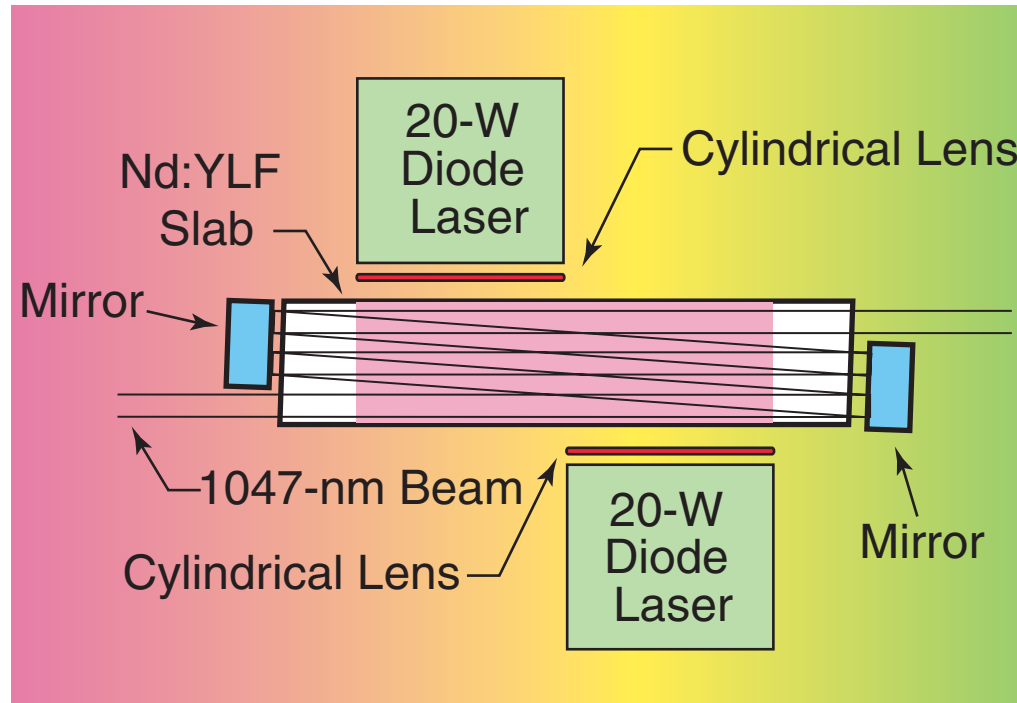

- **Multi-pass slab (MPS) gain module extracts a large fraction of the available power in a TEM₀₀ mode; high gain**
- **Simple single-element pump optics**

The Single-Frequency Seed Laser

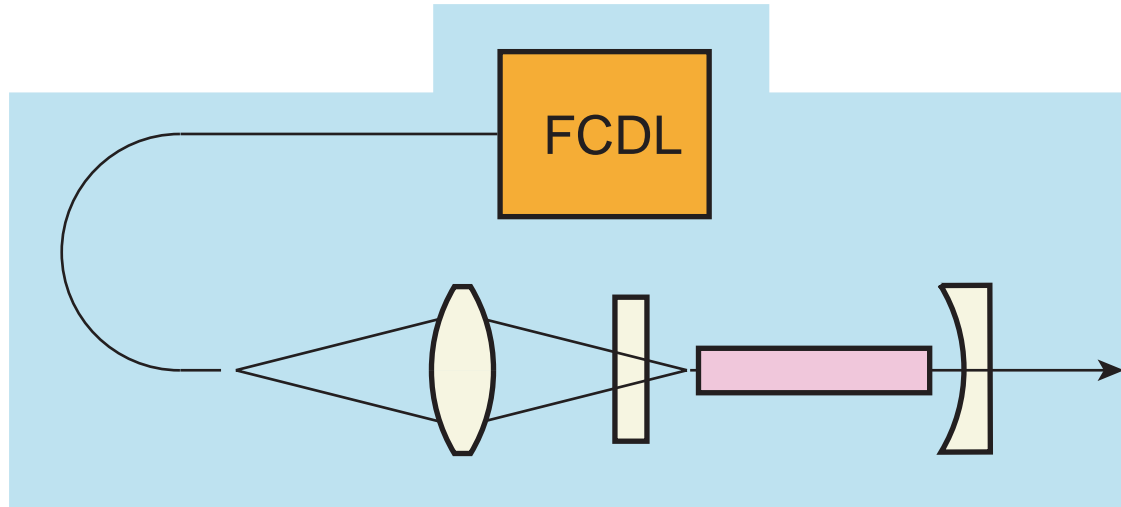

- **Proprietary Technology**
- **Output**
 - 10 mW
 - single longitudinal mode
 - TEM₀₀ (circularly symmetric)
 - 1047 or 1053 nm
- **Stability**
 - linewidth: < 10 kHz
 - passive stability: 150 MHz/°C
 - tuning range: 190 GHz
 - short term jitter: 280 kHz (in 200 ms)

The Single-Frequency MOPA System

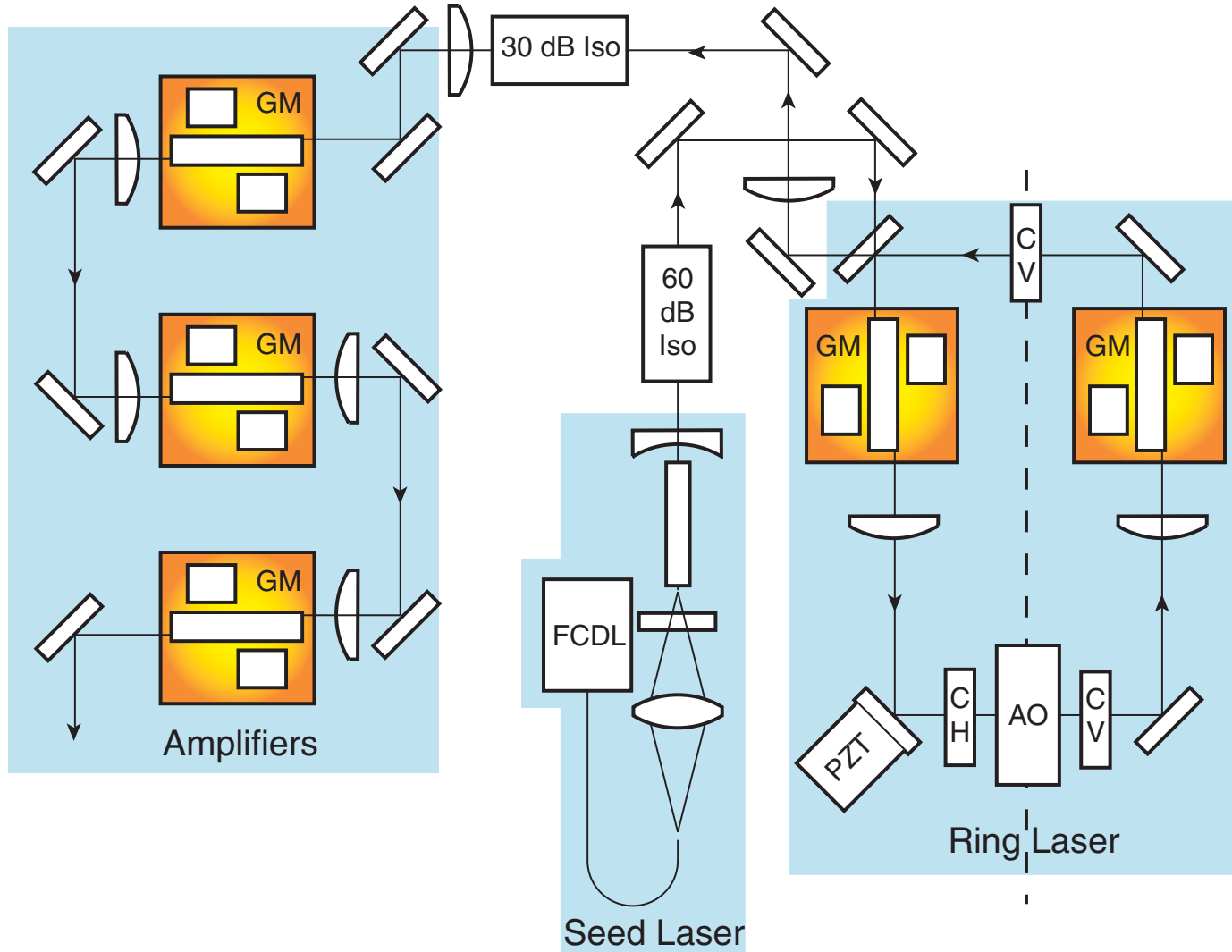

The Single-Frequency Ring Laser

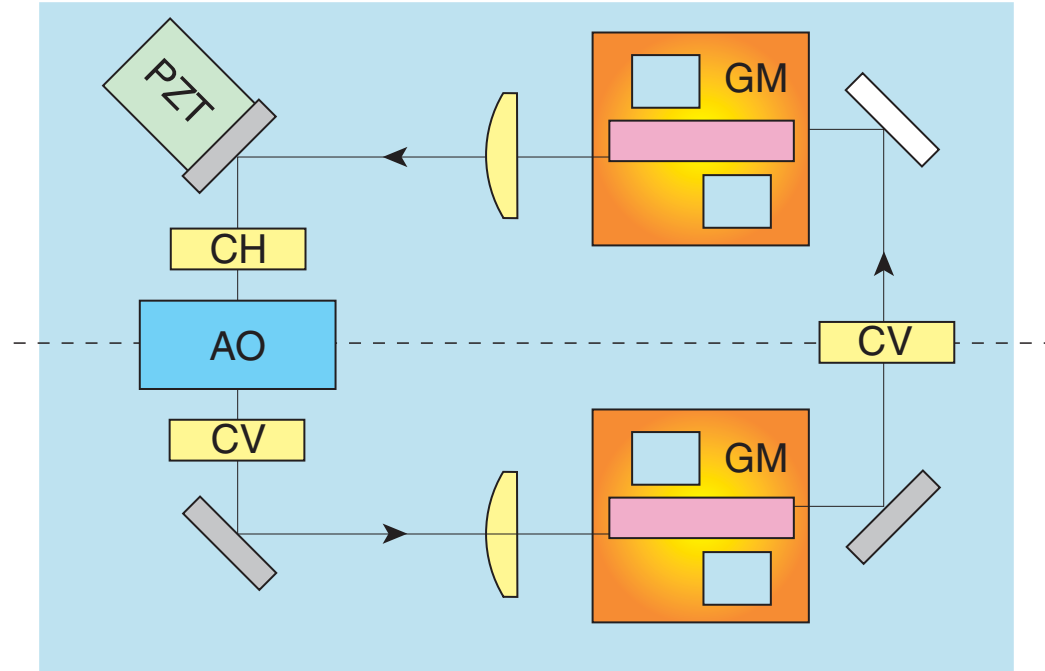

- “Symmetric” cavity design
- Cavity length minimized to obtain short pulses
- Cylindrical optics used to produce an astigmatic laser mode to efficiently extract gain

The Ring Laser Design

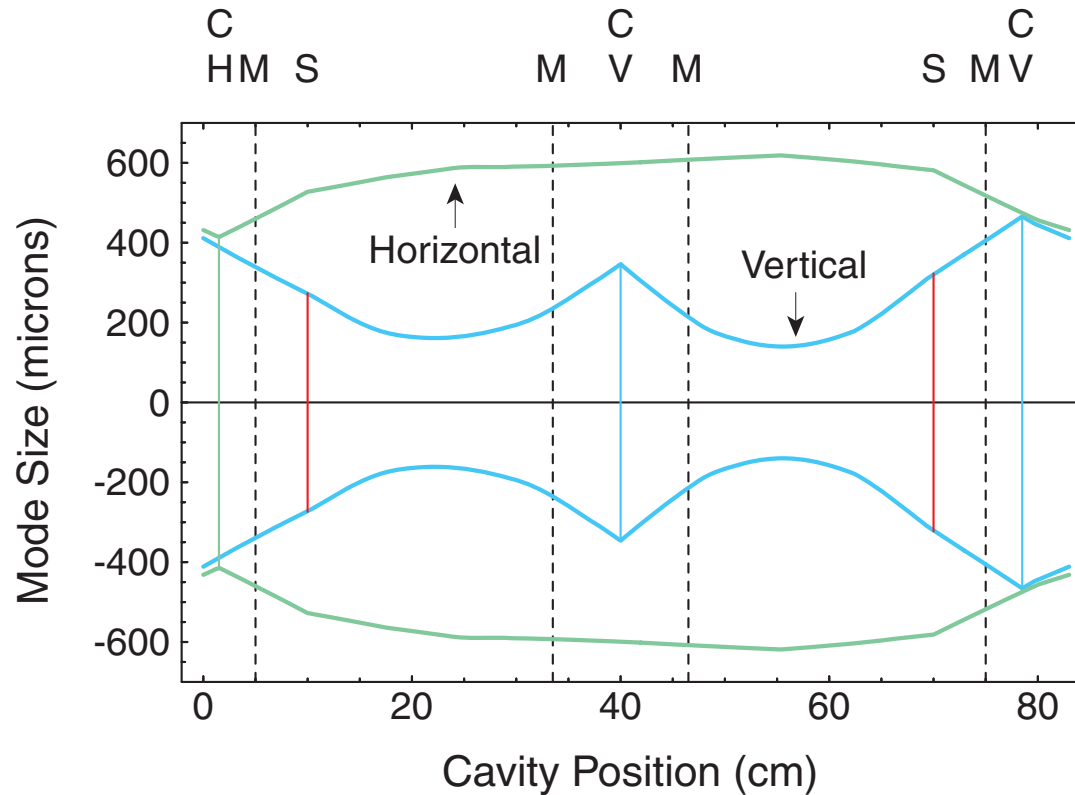

- The vertical mode size is matched to the gain sheet height
- The horizontal size is a trade-off between efficient extraction and diffraction

Leading Edge
of Optical
Pulse

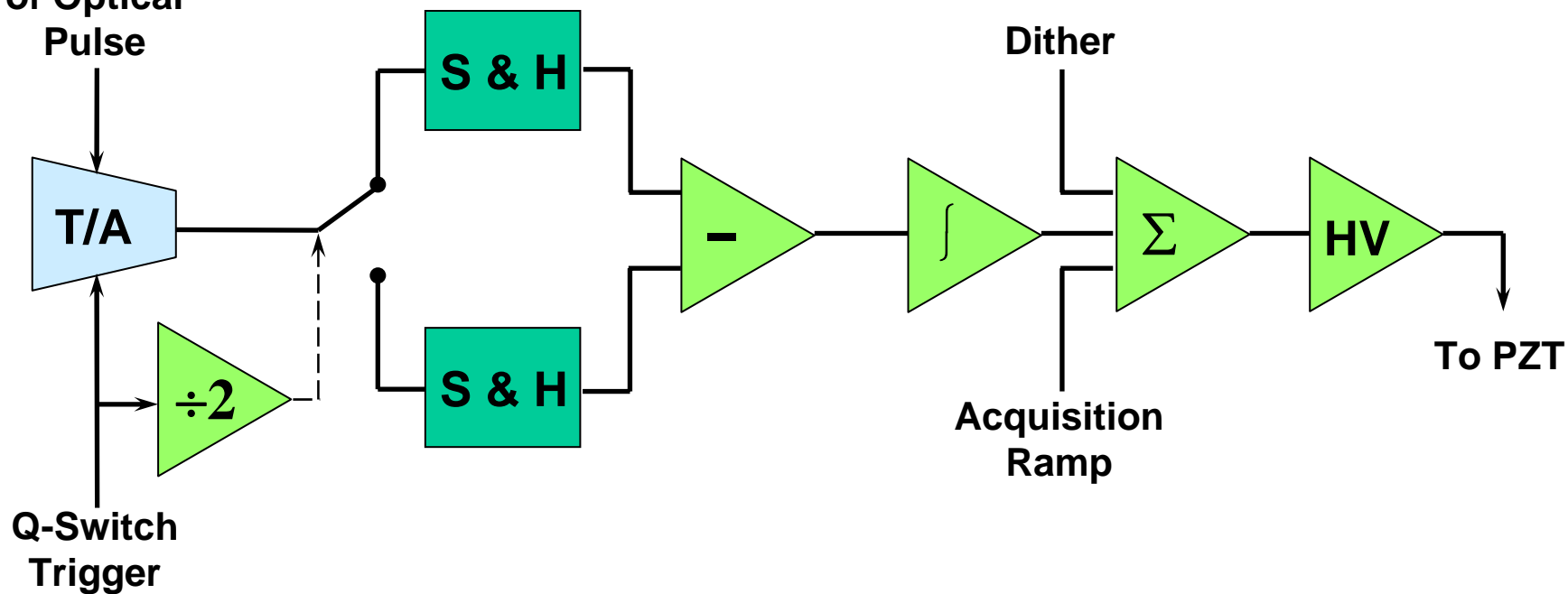

- When the seed laser frequency corresponds to a longitudinal mode of the slave laser, the build up time is the shortest.

The Linewidth of the Single Frequency Ring Laser is < 100 MHz (Resolution Limited)

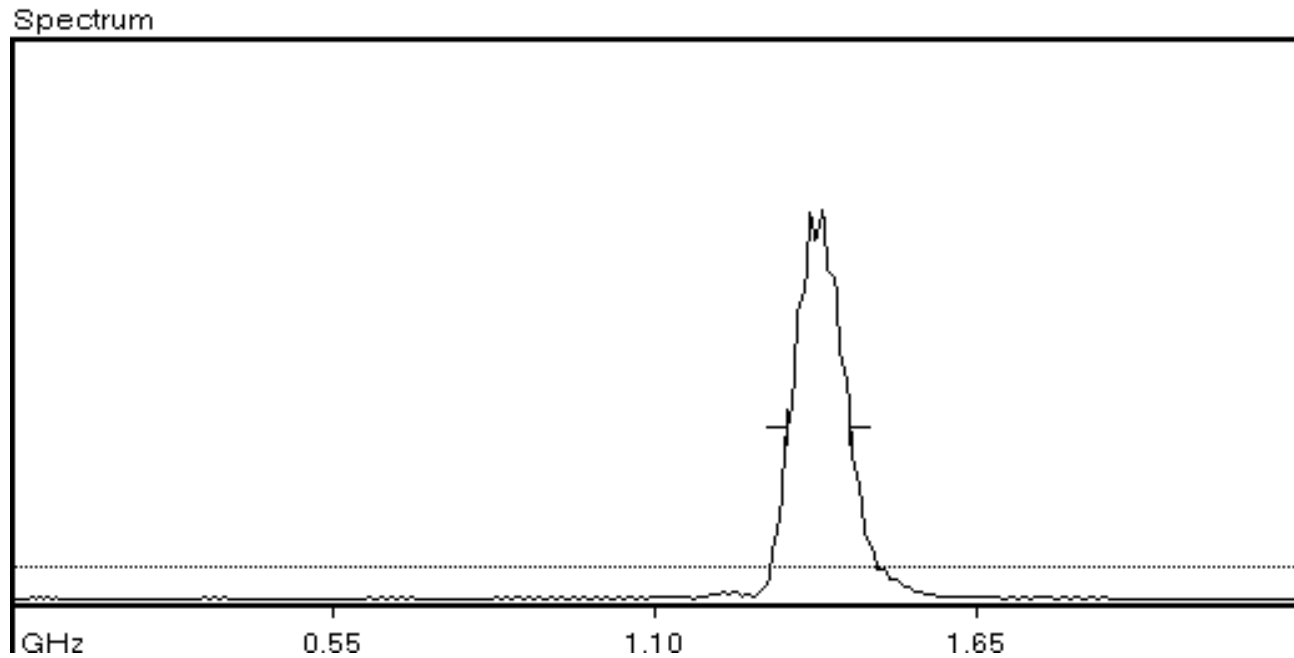

- Transform limited pulsewidth is ~ 20 MHz
- Measured with a Burleigh pulsed wavemeter

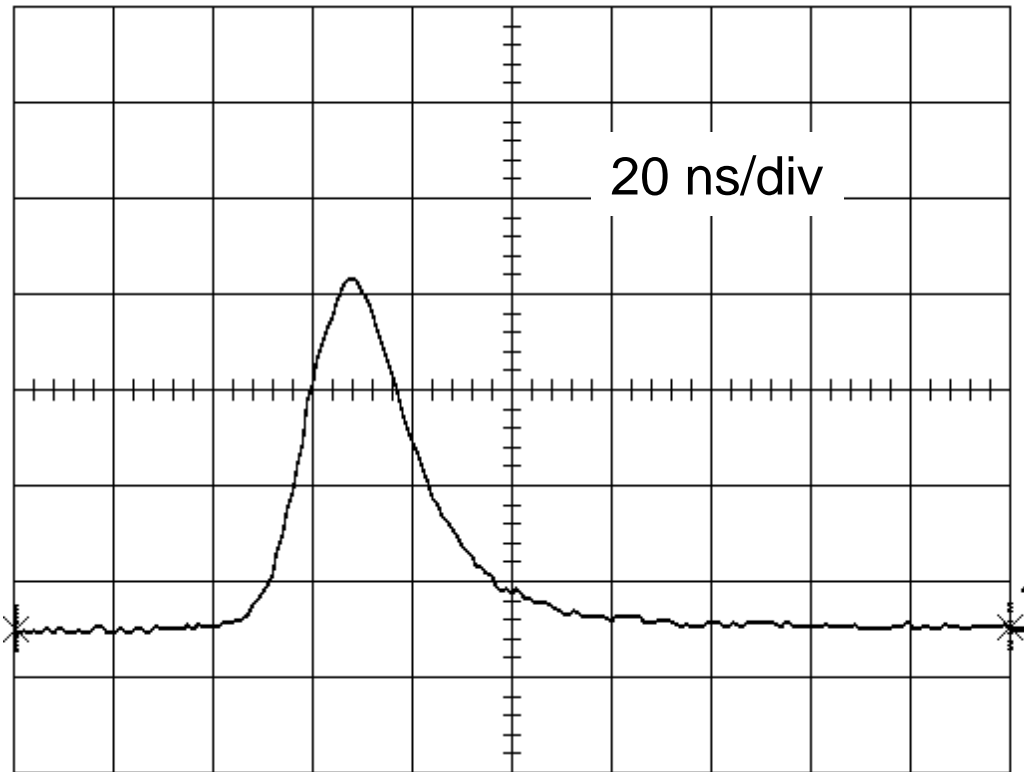

Oscilloscope

Analog Bandwidth: 1 GHz

Sampling Rate: 1 GHz

Detector

Risetime: < 200 ps

Falltime: < 350 ps

- **Smooth pulse shape implies no mode beating and single-longitudinal mode operation**

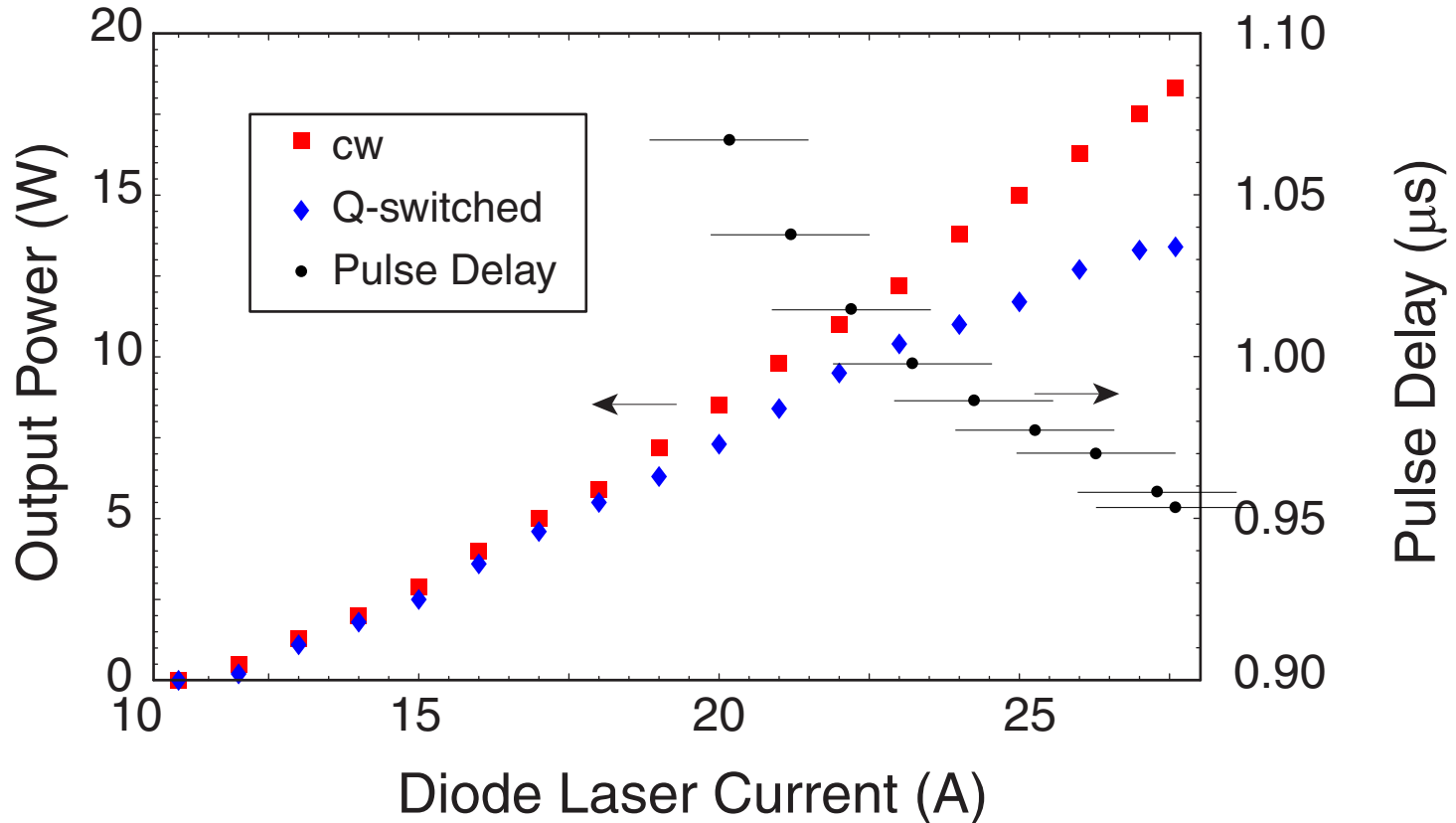

•Unseeded operation

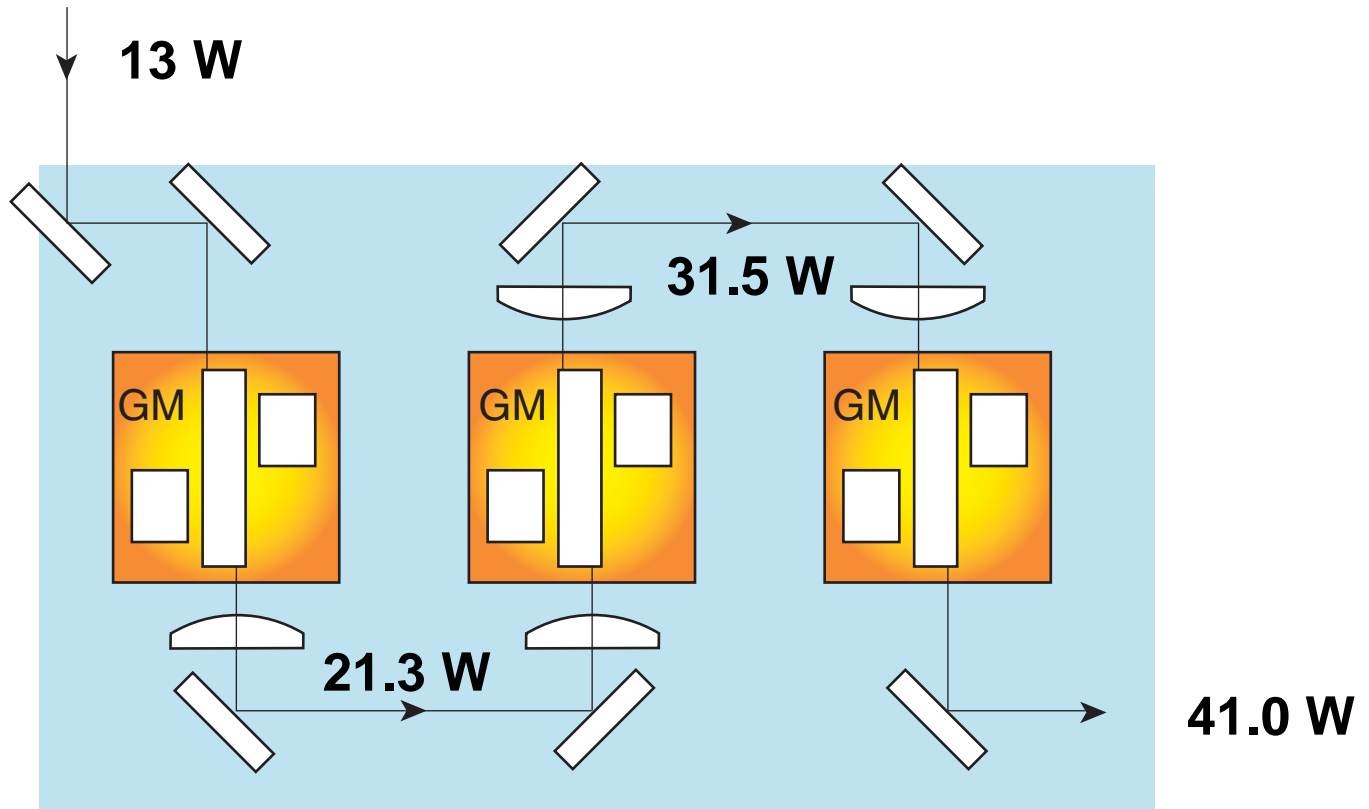

- Relay optics used between gain modules

Measured with Spricon
M²-101 Beam Analyzer

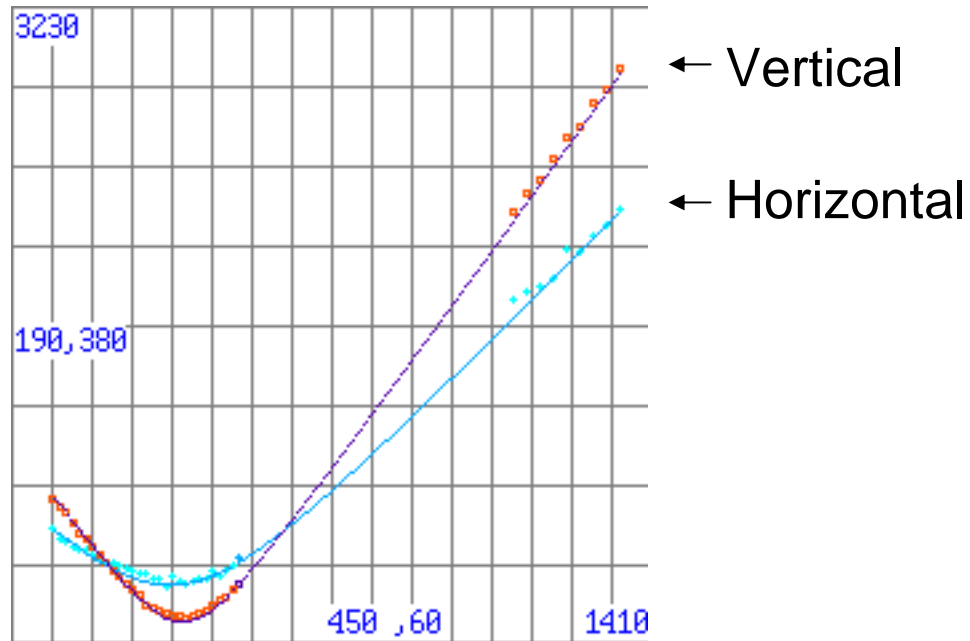

M² 1.17 (horizontal); 1.00 (vertical)
Astigmatism: 0.359
Asymmetry: 1.532

Pointing Stability:

$\pm 2 \mu\text{rad}$ (1 hr)

Polarization:

$> 600:1$

Power Stability:

$\pm 1.5\%$

Pulse Amplitude Stability:

$\pm 3.4\%$ (over 1000 pulses)

Pulse Jitter:

$\pm 1.3 \text{ ns}$ (over 1000 pulses)

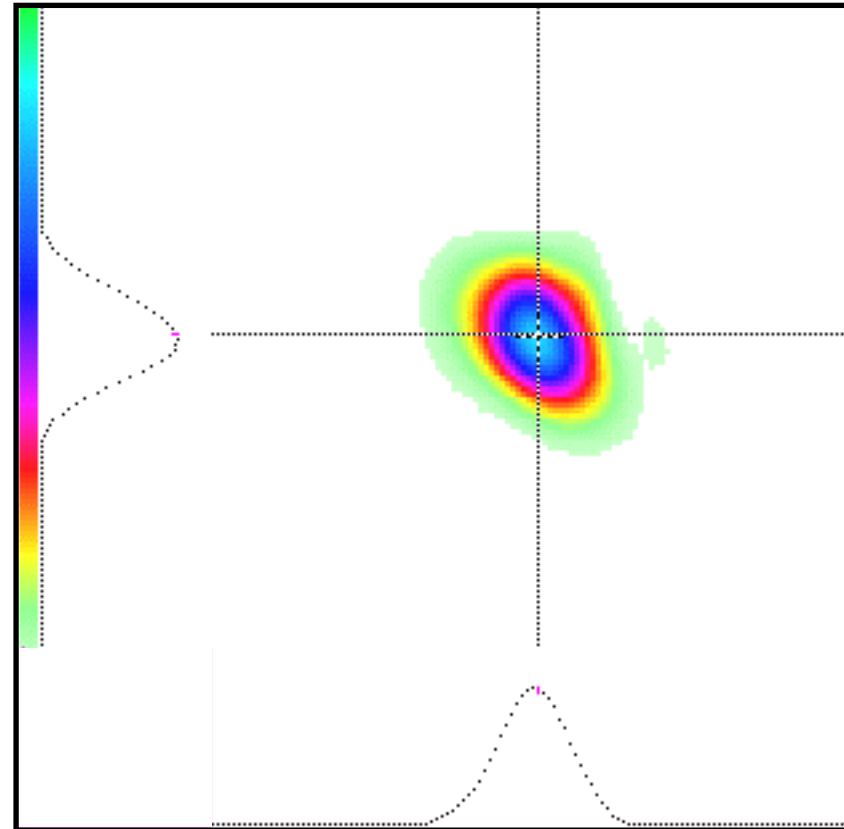

- **Nd:YLF MPS gain modules have been used to construct a ring laser Q-switched at 5-KHz with a time-averaged output power of 14.2.**
- **Using proprietary seed laser technology we have injection seeded using the pulse-build-up time reduction technique.**
- **At 5 kHz, we have amplified the ring laser to ~40 W with excellent beam quality ($M^2 < 1.2$).**
- **An unseeded system has produced 50-W (Q-switched at 5 KHz) and 60 W cw.**