

DEVELOPMENT OF TUNABLE/NOVEL SOLID STATE LASERS

**The Rank Prize Funds
Mini-Symposium on Solid State Lasers
3-6 April, 1995**



*RESEARCH
DIVISION*



*RESEARCH
DIVISION*

GENERAL OUTLINE

- **Ti:sapphire Lasers**
- **New Tunable Lasers**
- **Infrared Sources**
- **Evolution of CW Diode-Pumped Lasers**

Occasional history as well



RESEARCH
DIVISION

CREDITS FOR THE WORKERS

- **Glen Rines (Pulsed Ti:sapphire, OPOs)**
- **James Harrison (CW Ti:sapphire, Diode-pumping)**
- **David Welford (Mode-locking) *Imperial College***
- **John Flint (Infrared lasers)**
- **David Rines (Infrared lasers, OPOs)**
- **Andrew Finch (Mode-locking, infrared lasers) *Oxford, St. Andrews***
- **Henry Zenzie (Cr:LiSAF, OPOs)**
- **Bradley Dinerman (Infrared lasers)**
- **Yelena Isyanova (OPOs, Diode-pumping)**
- **Richard Schwarz (Pulsed Ti:sapphire)**



RESEARCH
DIVISION

WHAT HAPPENED IN THE 60'S

- n **Transition-metal ions**
 - **Cr, Ni, Co, V**
- n **Rare-earth ions**
 - **Nd, Ho, Tm, Er, Yb**
- n **Sensitized lasers**
- n **Upconversion lasers**
- n **Laser-pumped lasers**
- n **Diode-pumped lasers**

- n **The "ings"**
- n **Monolithic lasers**
 - **ruby!**
- n **Unidirectional rings**
- n **Efficient harmonics**
 - **External, internal**
- n **Parametric oscillators**
- n **"Slab" geometry?**



RESEARCH
DIVISION

Ti:SAPPHIRE LASERS - OUTLINE

Brief history

Lamp-pumped devices

CW-pumped systems

- **All-solid-state**
- **Repetitively Q-switched**
- **Mode-locked**

Pulse-pumped devices

Non-linear conversion for wavelength extension

Other Ti hosts



RESEARCH
DIVISION

TECHNOLOGY GENEALOGY

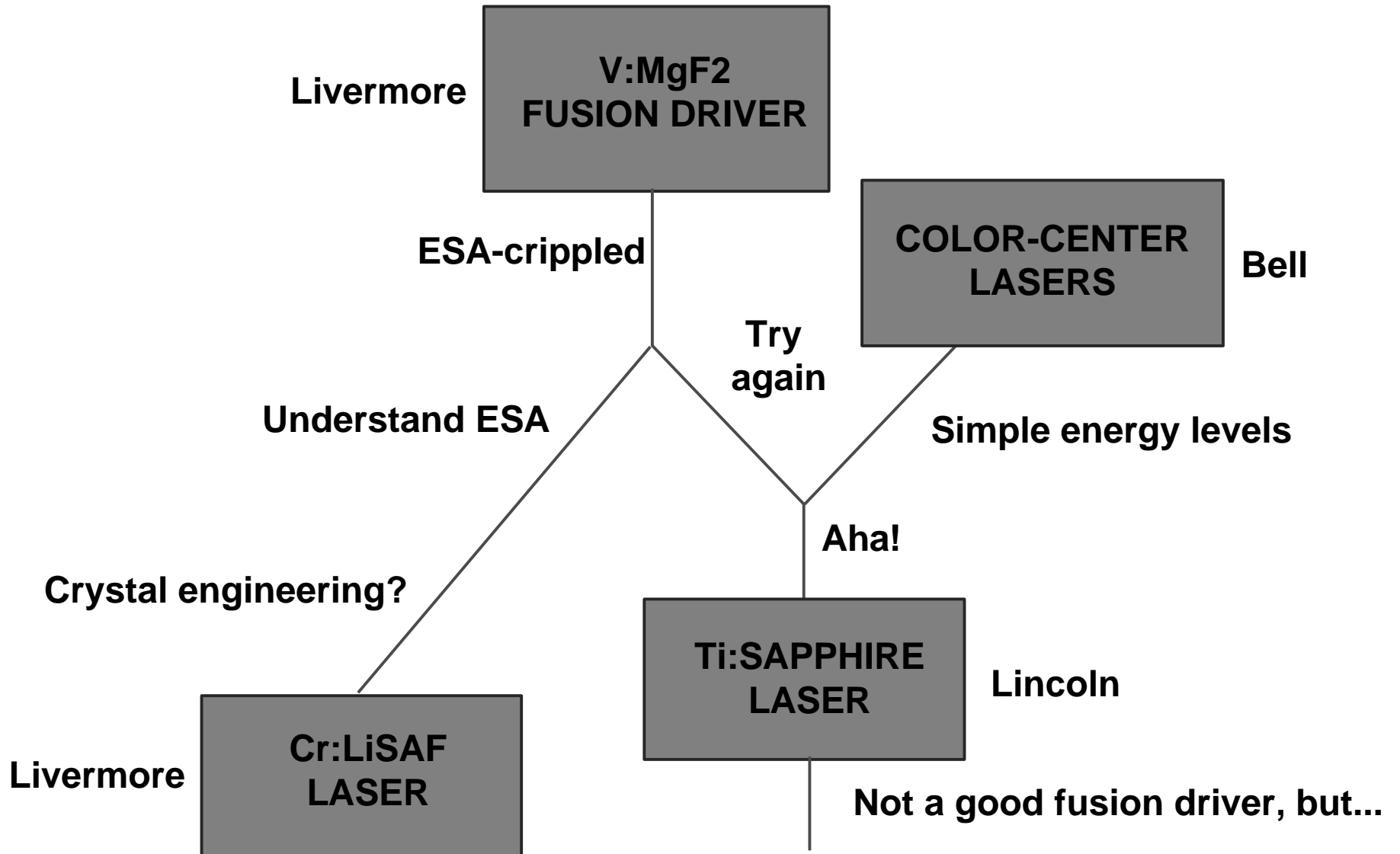



RESEARCH
DIVISION

PULSED Ti:SAPPHIRE LASER - TUNING CURVE

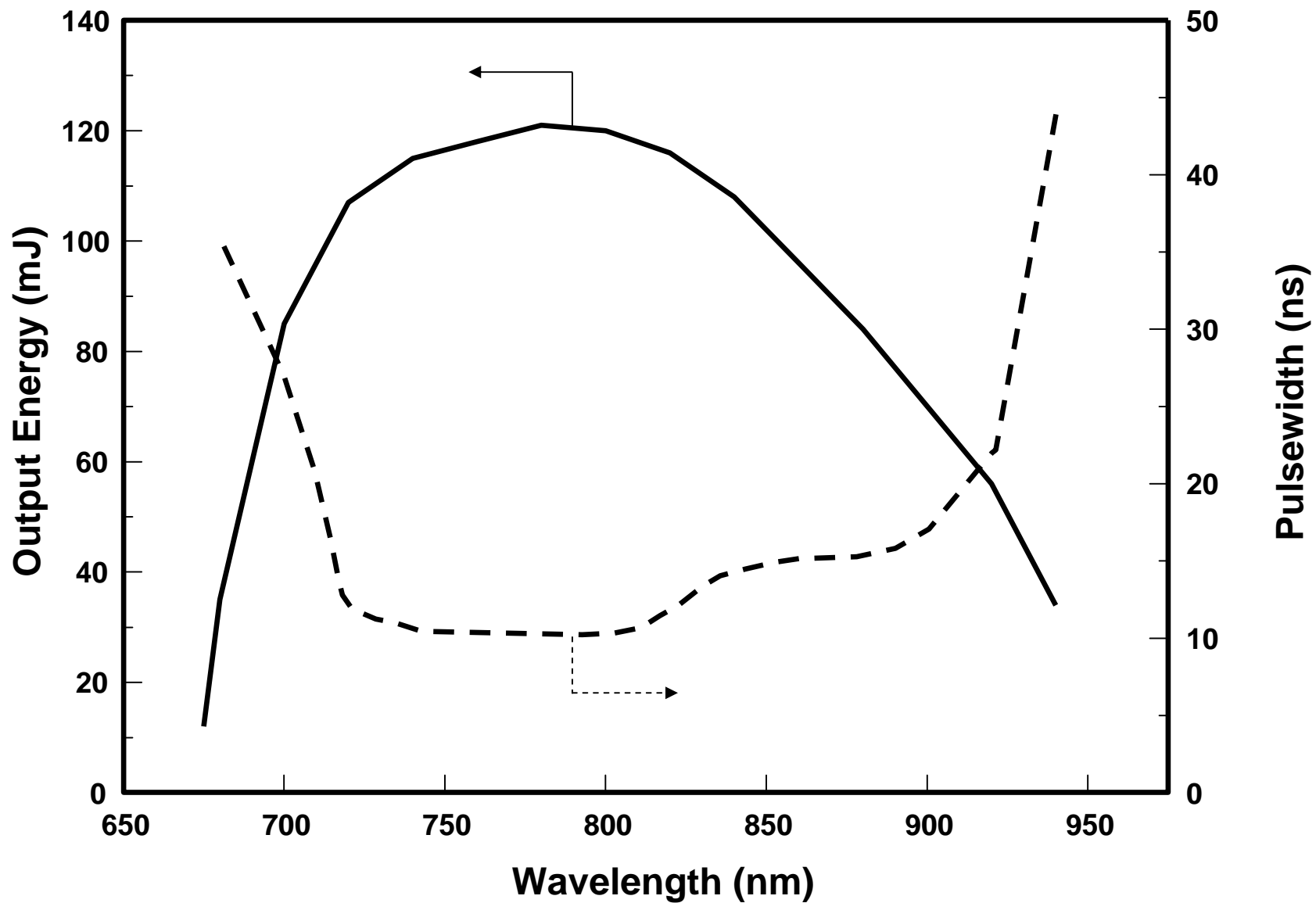



RESEARCH
DIVISION

TUNING CURVE - SHG Ti:SAPPHIRE

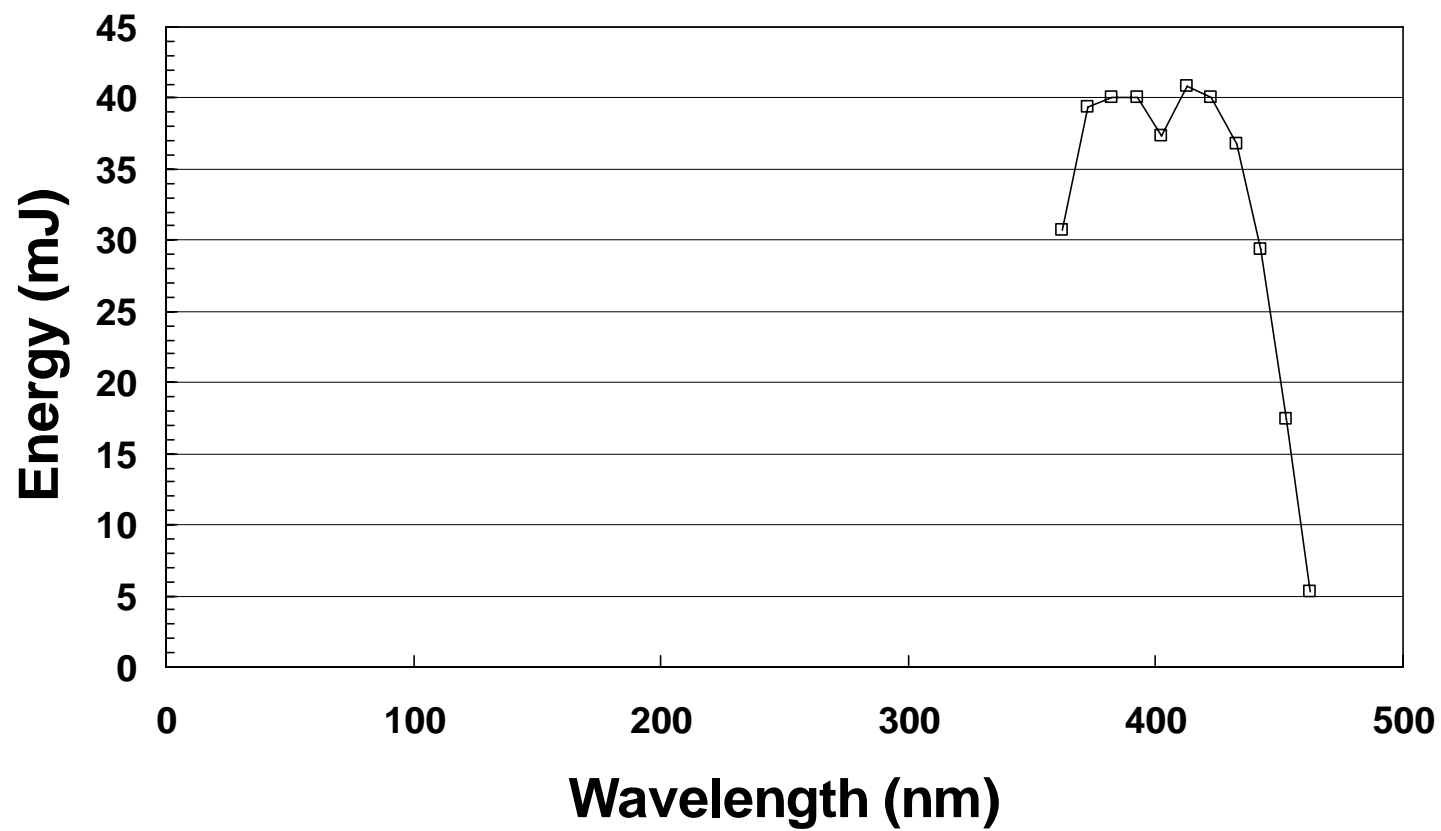



RESEARCH
DIVISION

PULSED Ti:SAPPHIRE - THIRD HARMONIC

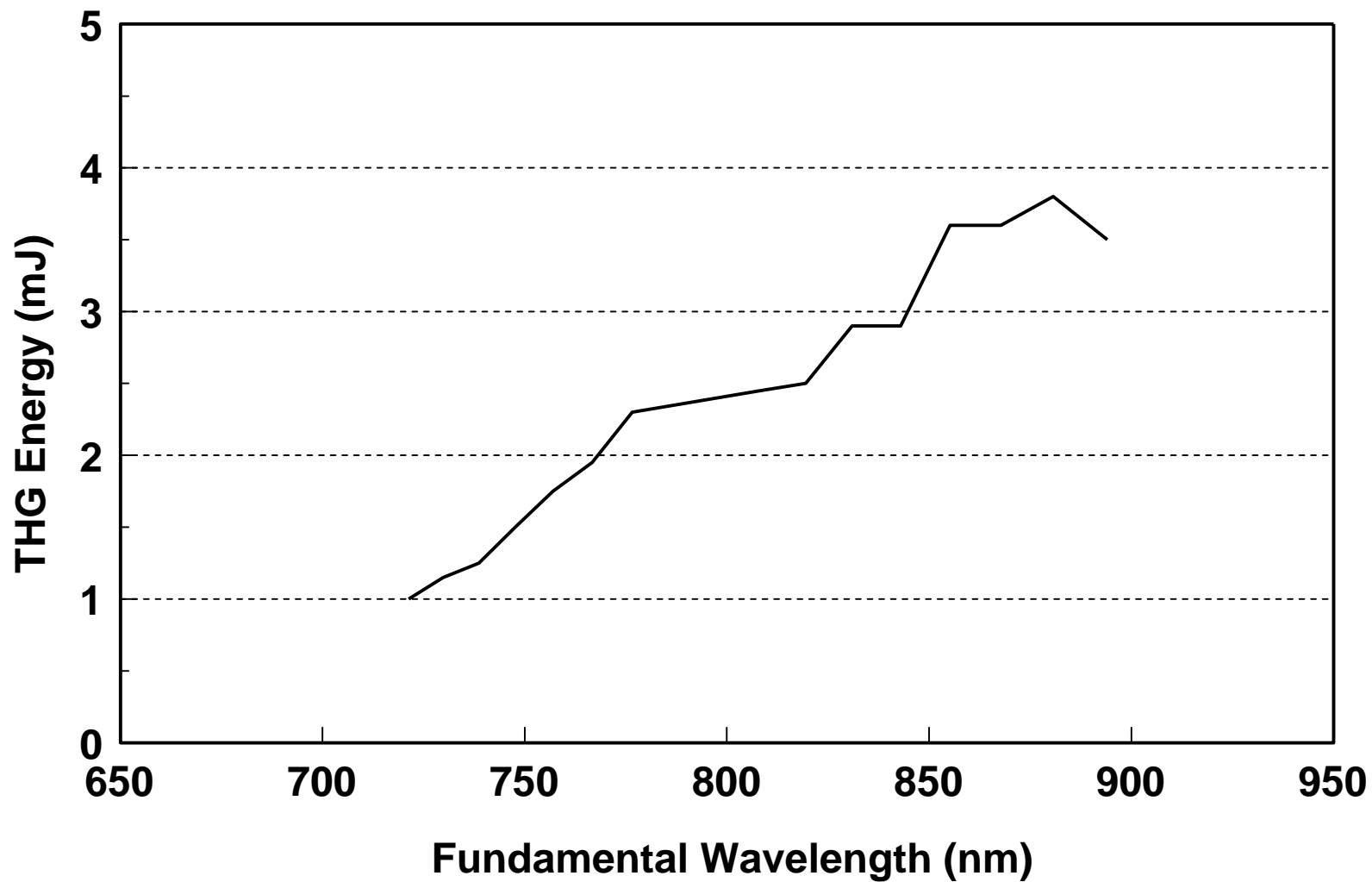



RESEARCH
DIVISION

PULSED Ti:SAPPHIRE - FOURTH HARMONIC

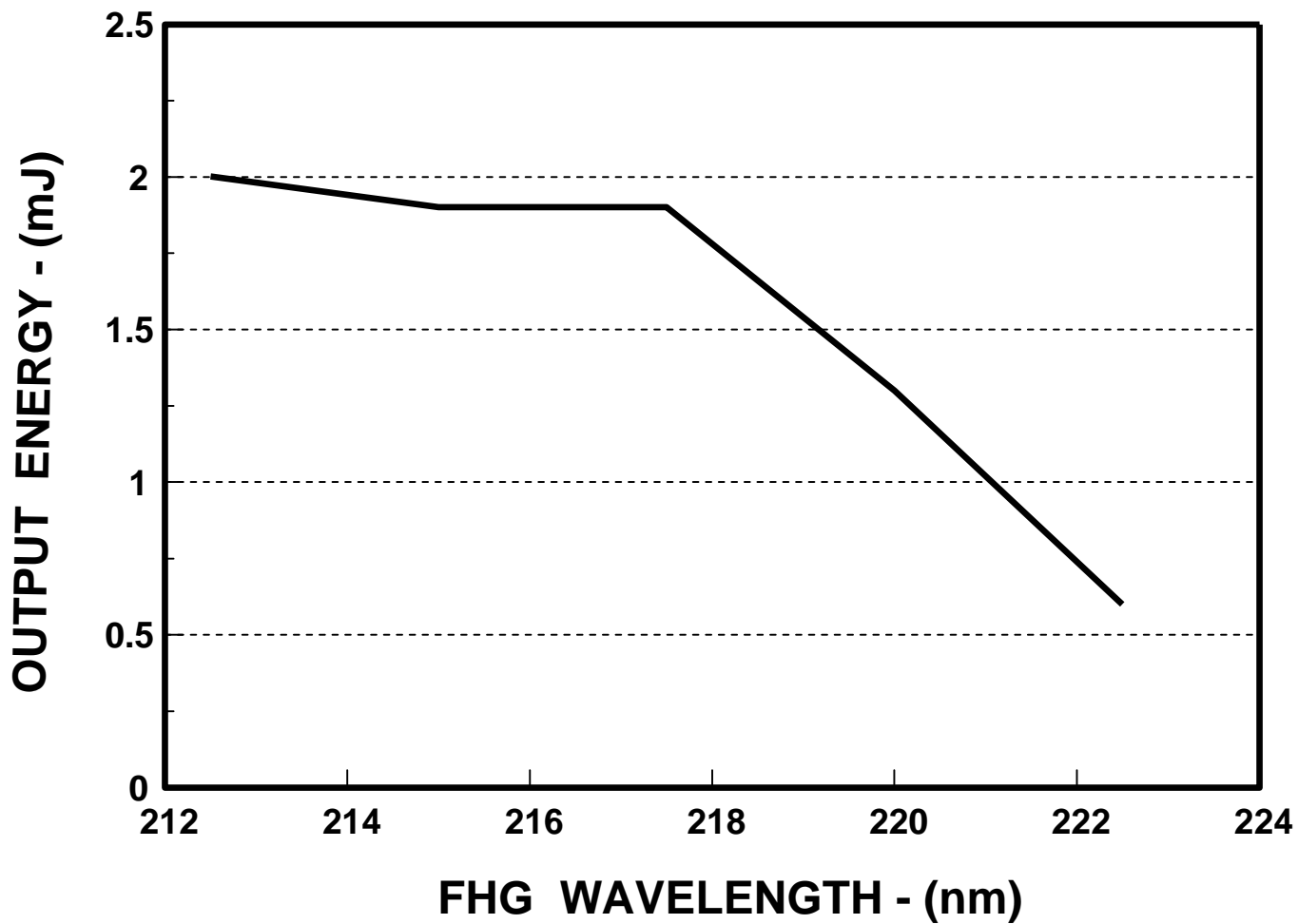



RESEARCH
DIVISION

GENERIC Ti:SAPPHIRE-PUMPED OPO

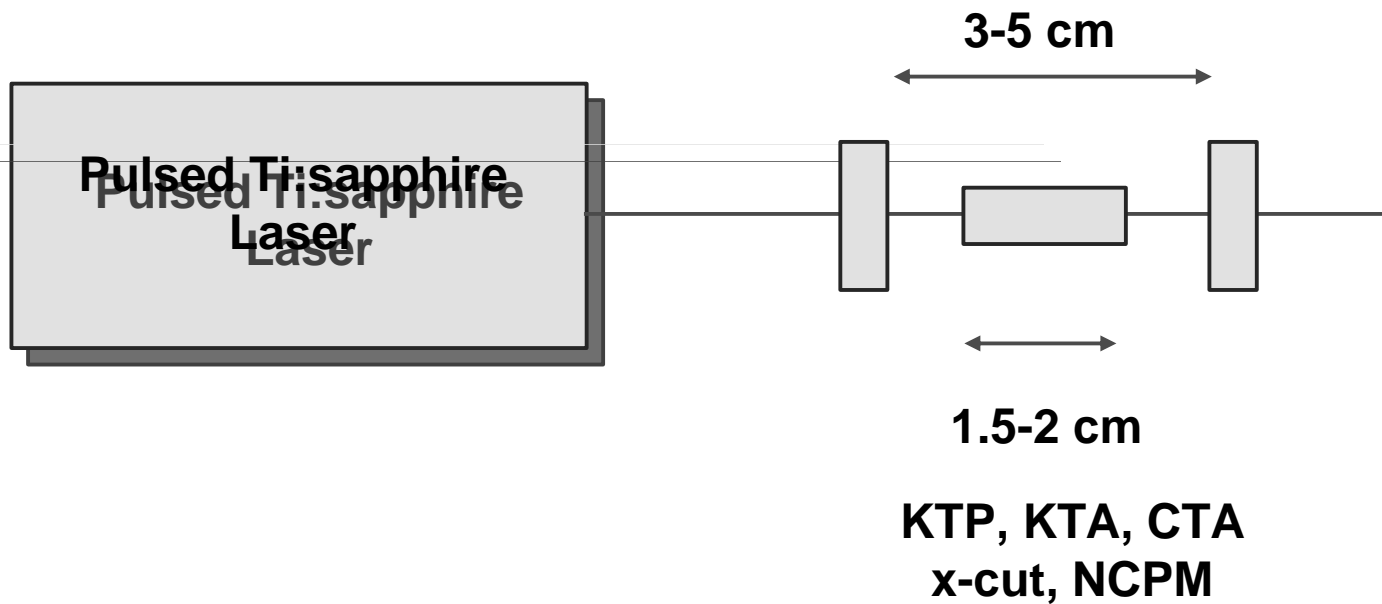

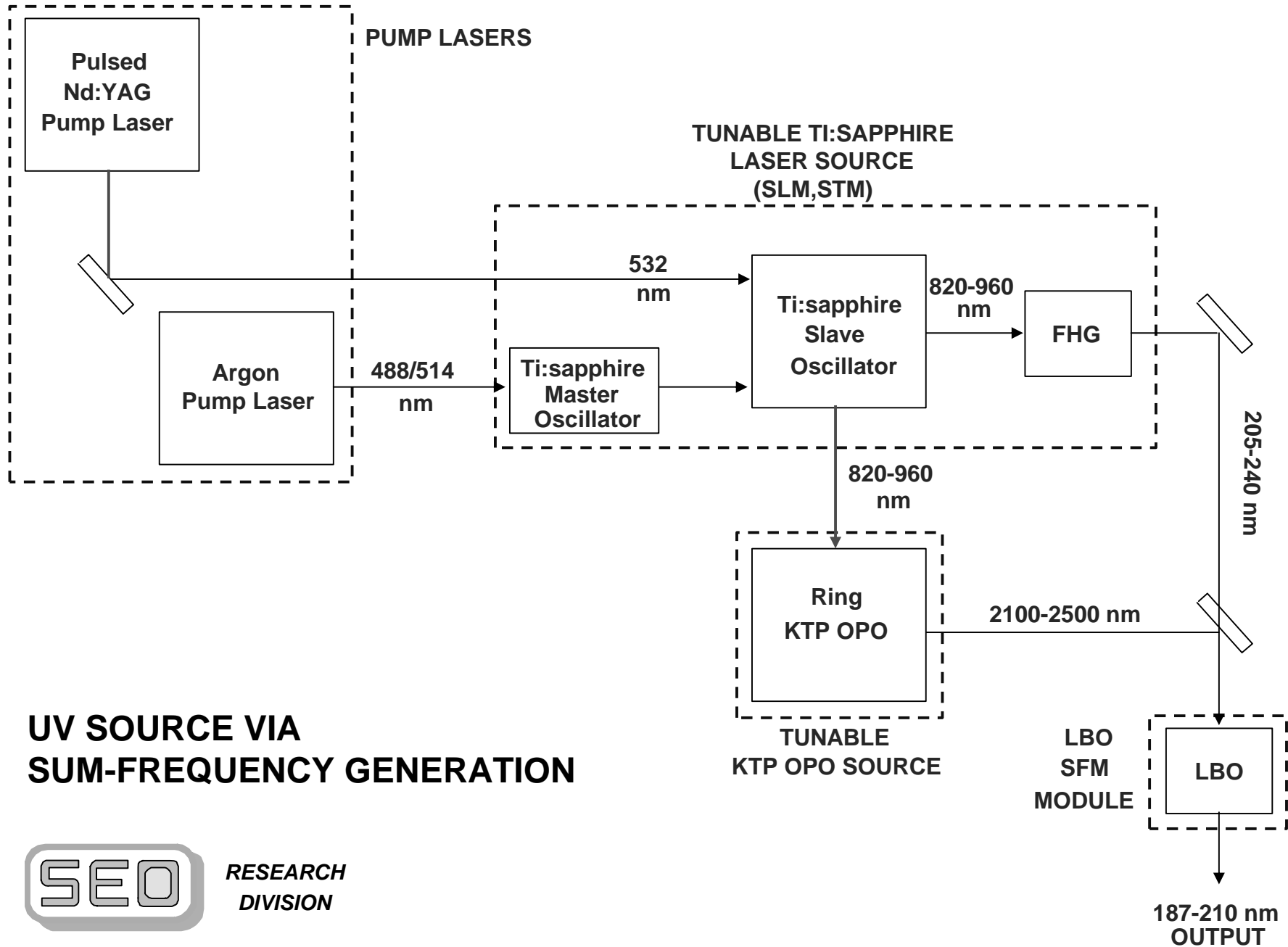

UV SOURCE VIA SUM-FREQUENCY GENERATION



RESEARCH
DIVISION



RESEARCH
DIVISION

TREND IN MODE-LOCKED Ti:SAPPHIRE PULSE DURATION

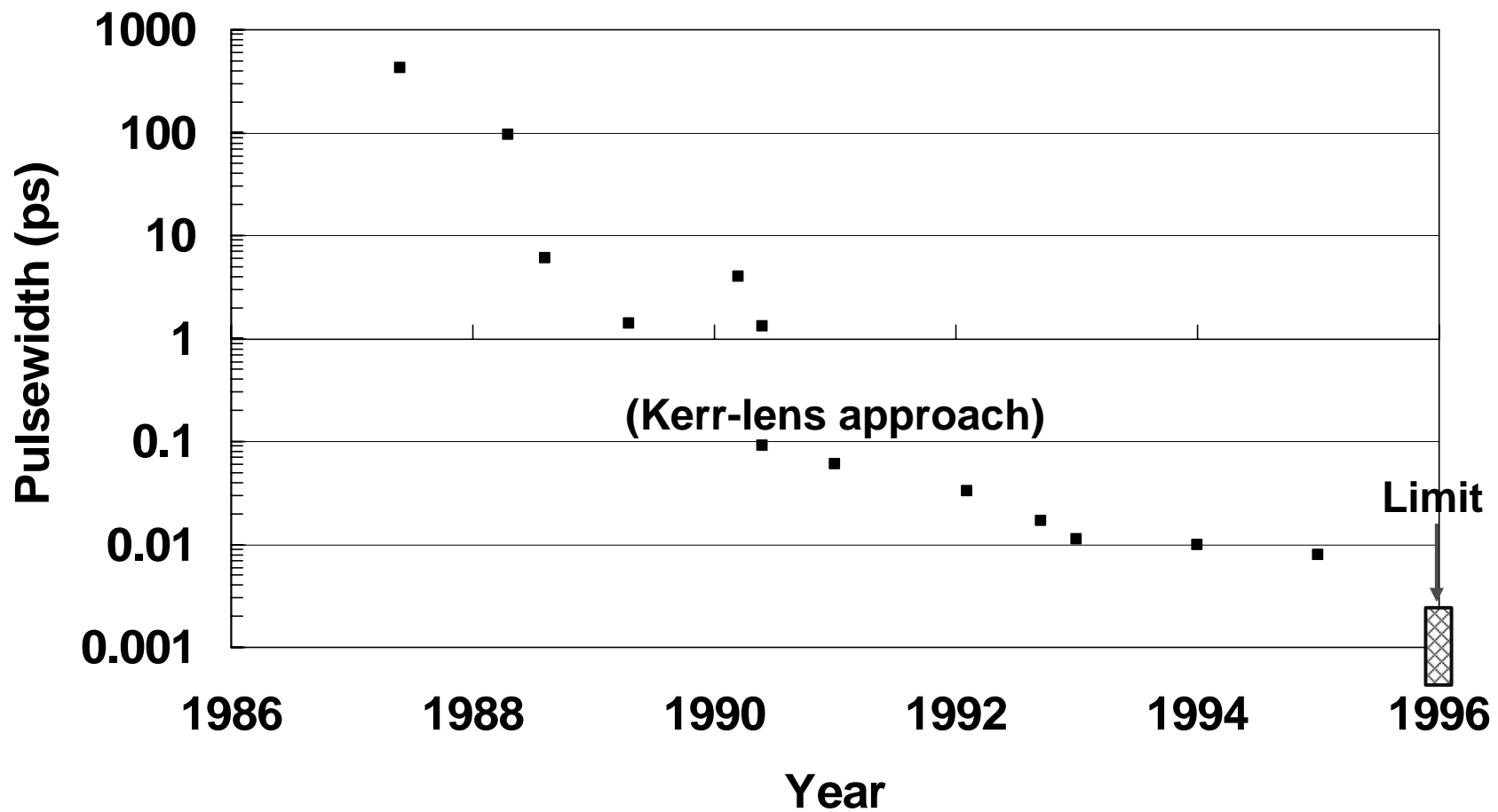



*RESEARCH
DIVISION*

NEW TUNABLE LASERS - OUTLINE

Cr:LiSAF

- **Lamp-pumped, high energy system**
- **Harmonic generation**
- **CW, diode pumped**

Cr:YAG

- **Pass**



DATA ON LAMP-PUMPED Cr:LiSAF

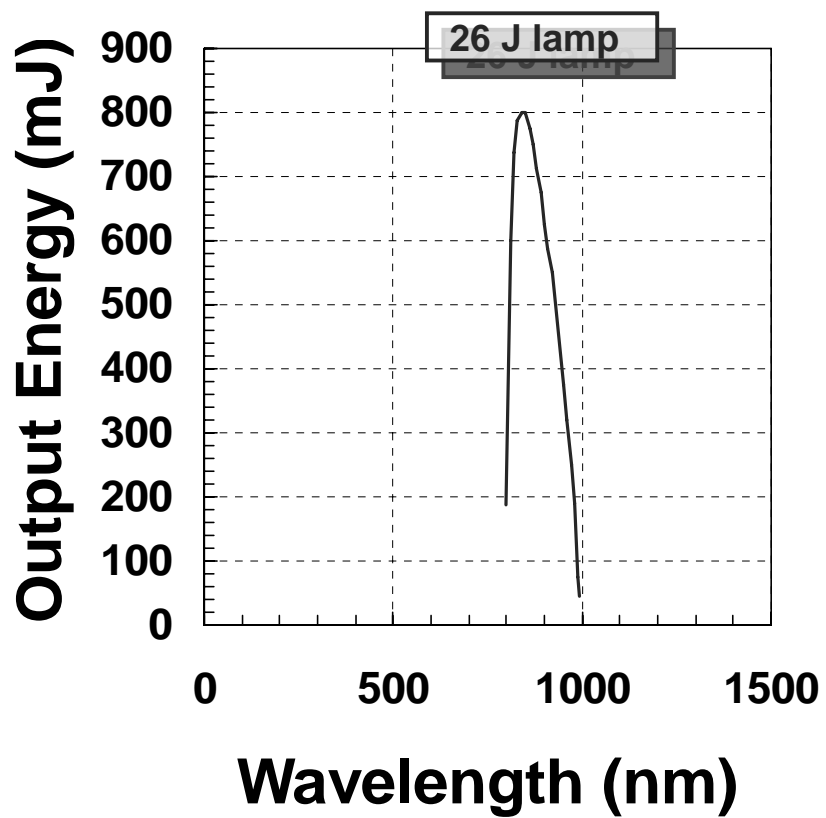

—□— LONG PULSE
- -◇- - Q - SWITCHED

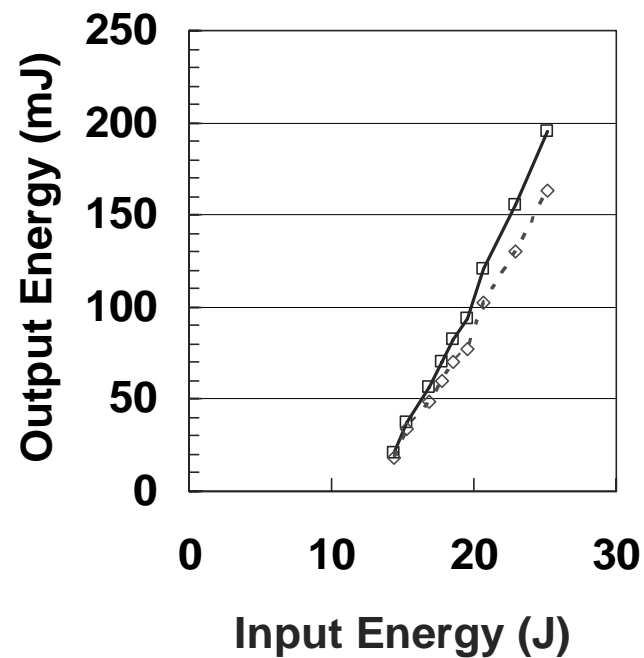



RESEARCH
DIVISION

Cr:LiSAF OSC-AMP SYSTEM

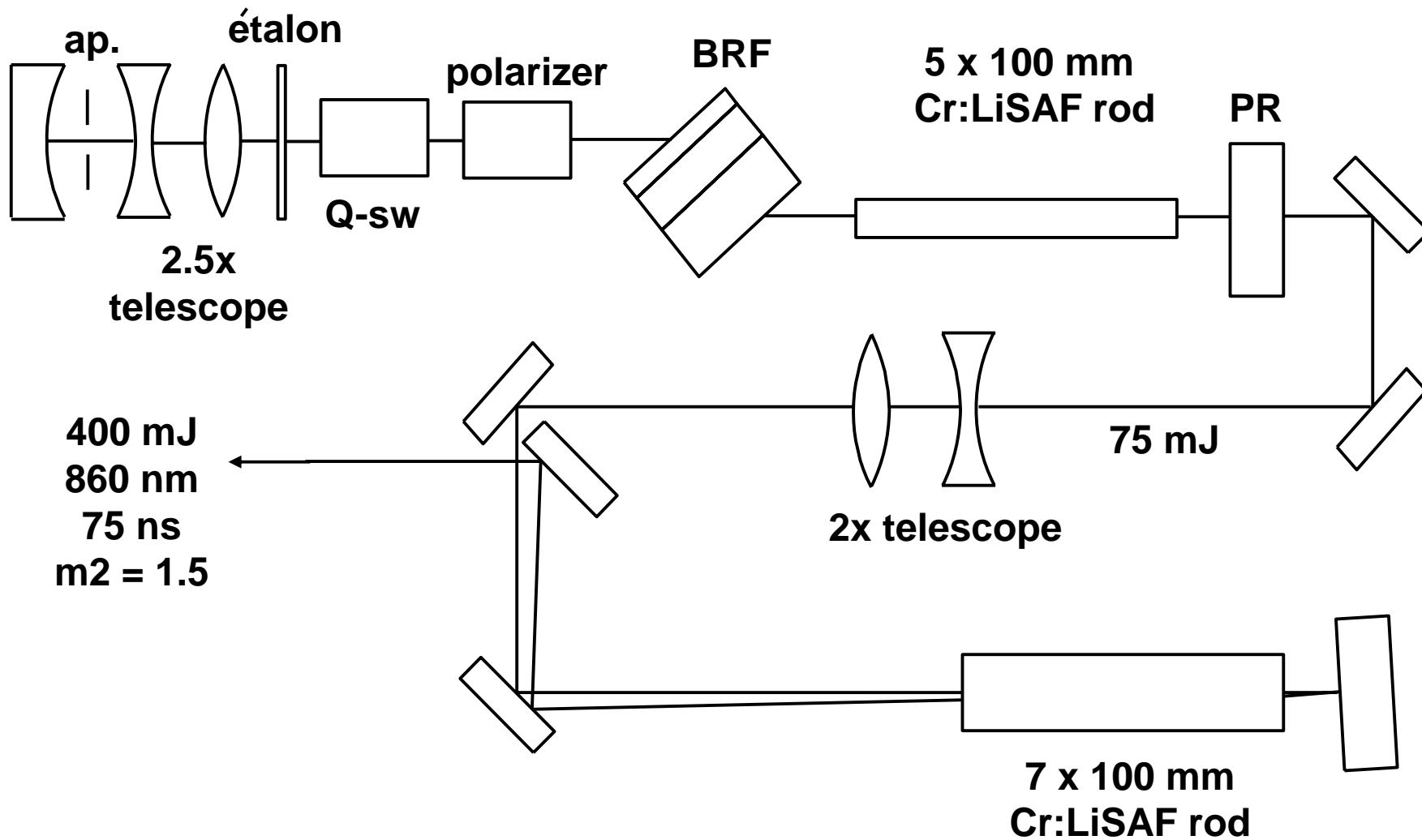



RESEARCH
DIVISION

Cr:LiSAF HARMONIC GENERATION CHAIN

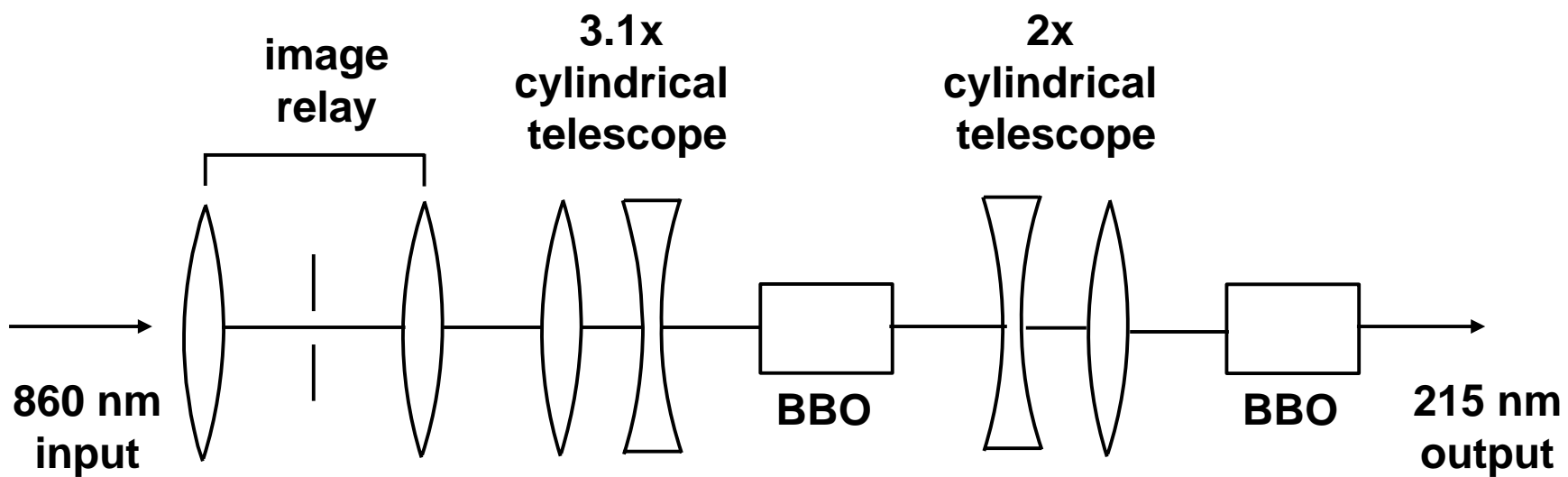



RESEARCH
DIVISION

Cr:LISAF HARMONIC GENERATION - DATA

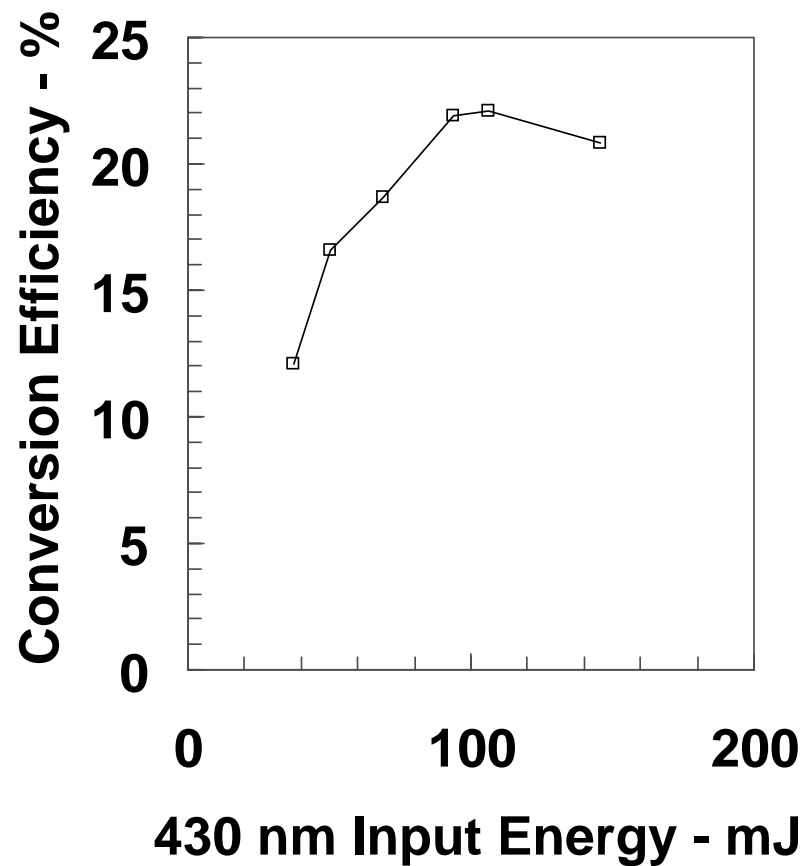
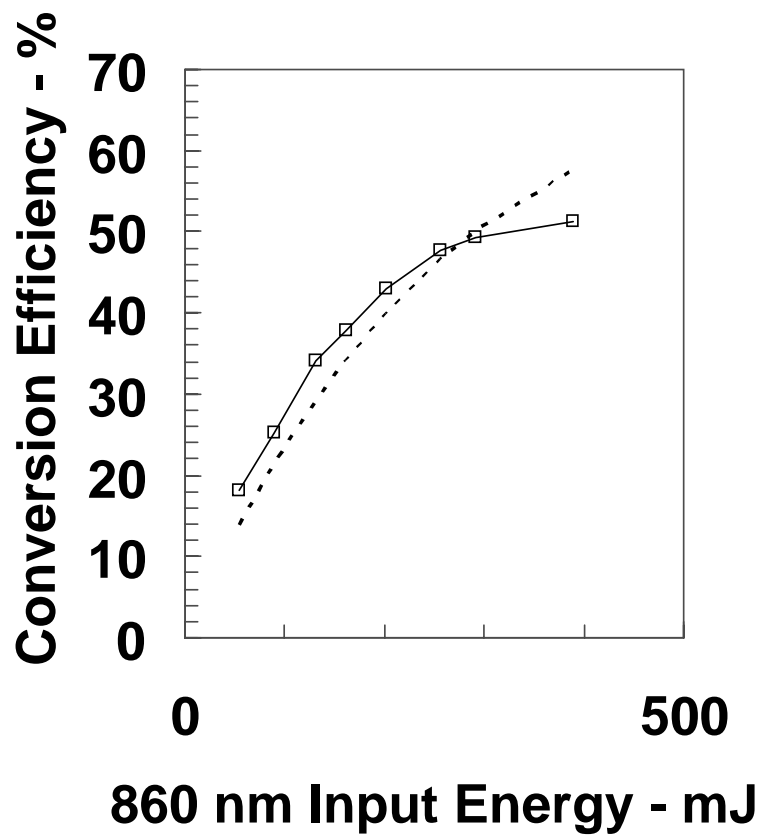



RESEARCH
DIVISION

DIODE-PUMPED Cr:LiSAF LASER SCHEMATIC

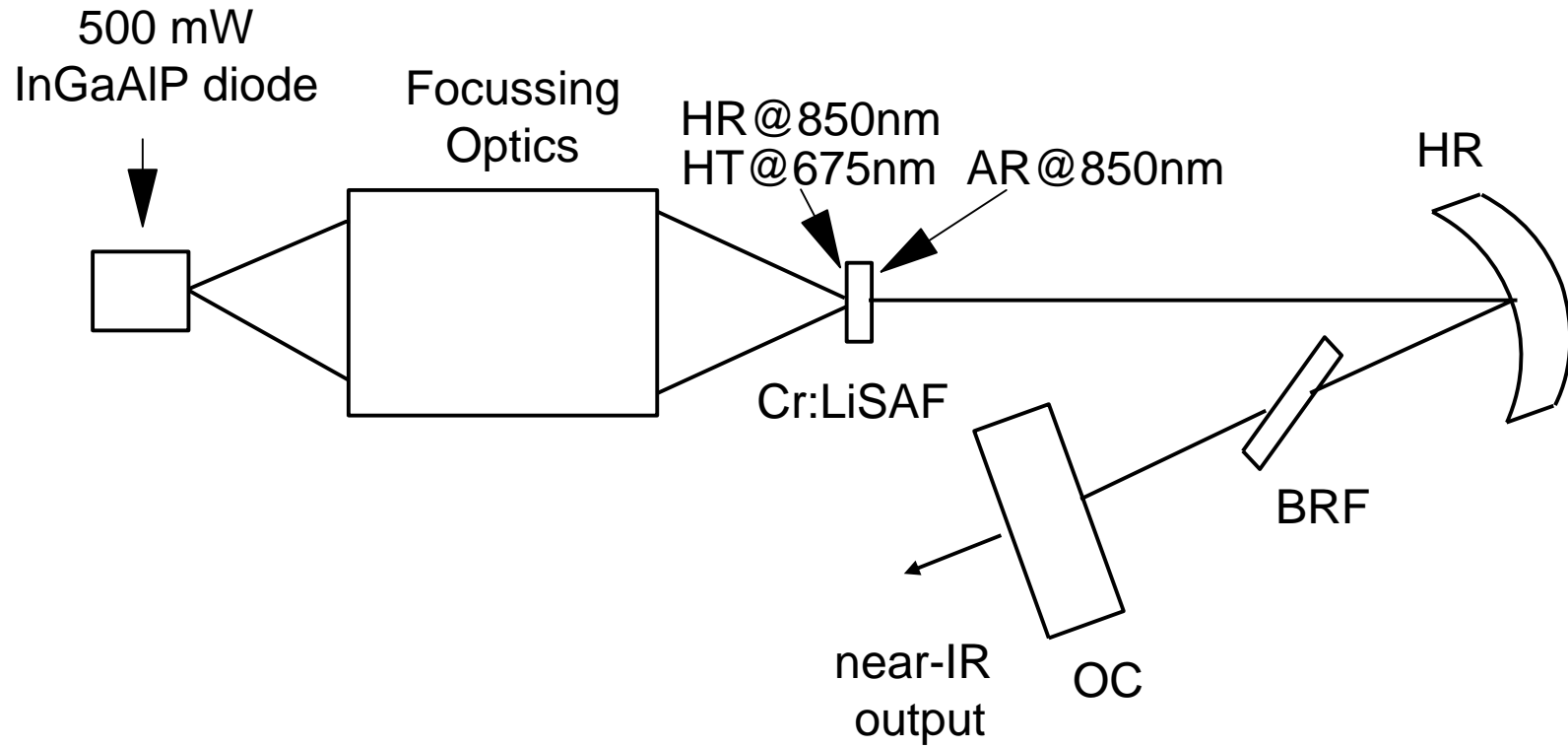



RESEARCH
DIVISION

INFRARED SOURCES - OUTLINE

Lasers

Lamp-pumped, rare-earths

Holmium

Erbium

Diode-pumped, rare-earths

Ditto

Nonlinear devices

Nd-laser-pumped, KTP OPOs

Erbium-laser-pumped CdSe OPO



RESEARCH
DIVISION

DATA ON HIGH-POWER Er:YAG LASER

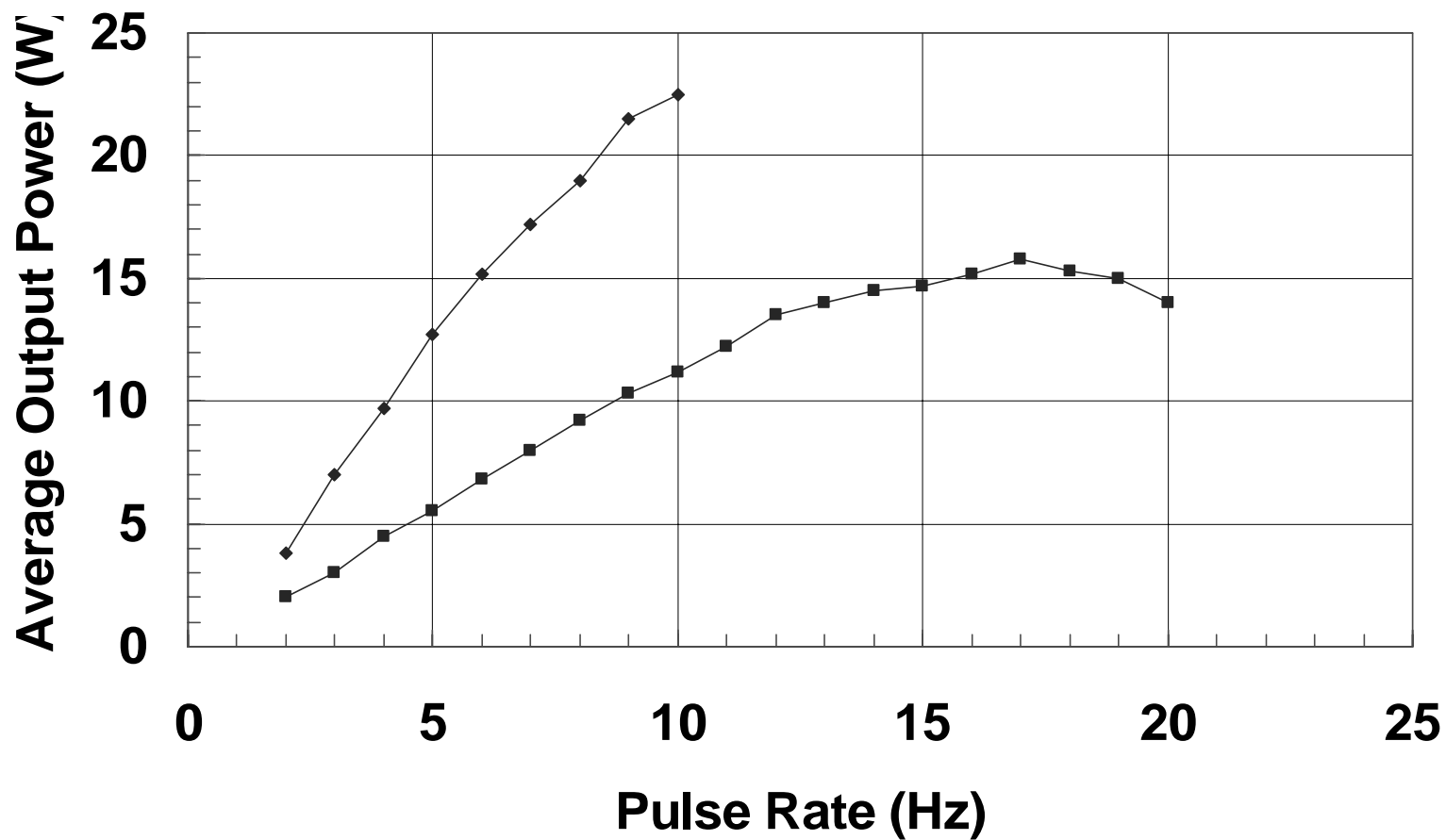



RESEARCH
DIVISION

CW DIODE-PUMPED Nd-DOPED LASERS - OUTLINE

"Single aperture," end-pumped, single-frequency sources

End pumping with linear array bars

- **Micro-lens optics**
- **Fiber-coupling optics**

Higher-power systems



RESEARCH
DIVISION

DIODE BAR OPTICS FOR END-PUMPING

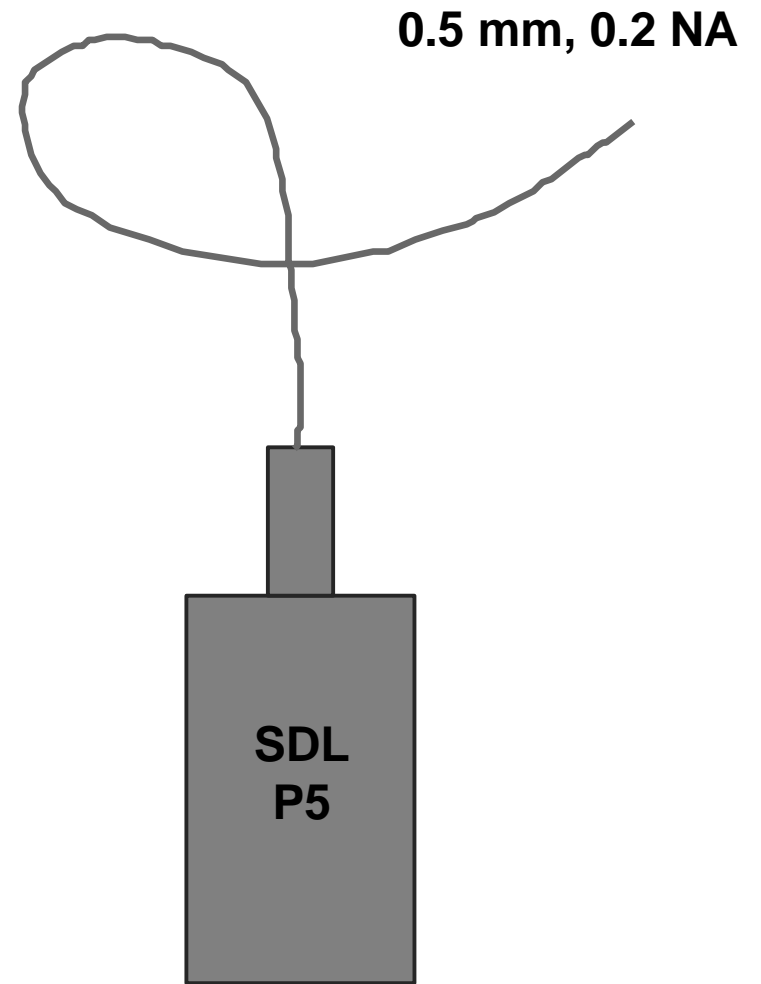
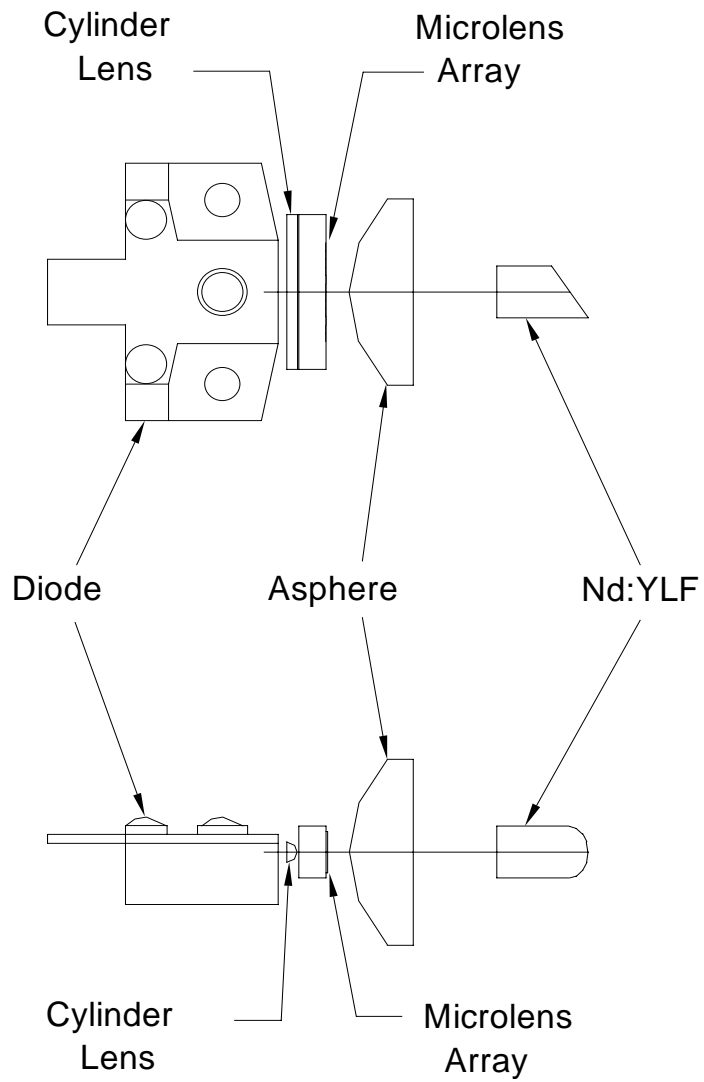



Research and development in solid state lasers can be split into two categories:

- Generic laser/nonlinear concepts**
- Materials**

There is no lack of concepts available, and many are often re-discovered, especially since work began 35 years ago

Materials discoveries/development have a more dramatic effect on advancement and are more random in nature, especially because of the funding mechanisms

High power semiconductor lasers are both beneficial and threatening to the field - future development should emphasize areas where overlap is unlikely